

3GPP2 C.S0015-B

Version ~~12.0.021~~

Date: ~~May 12~~~~October 19, 2004~~~~January 14~~
~~September 30, 2005, 2005~~



3RD GENERATION
PARTNERSHIP
PROJECT 2
"3GPP2"

Short Message Service (SMS) for Wideband Spread Spectrum Systems

Release B

COPYRIGHT

3GPP2 and its Organizational Partners claim copyright in this document and individual Organizational Partners may copyright and issue documents or standards publications in individual Organizational Partner's name based on this document. Requests for reproduction of this document should be directed to the 3GPP2 Secretariat at secretariat@3gpp2.org. Requests to reproduce individual Organizational Partner's documents should be directed to that Organizational Partner. See www.3gpp2.org for more

information.

No text.

PREFACE

These technical requirements form a standard for a Short Message Service (SMS), providing delivery of text and numeric information for paging, messaging, and voice mail notification. This standard includes Service Option 6 and Service Option 14 (as defined in [15]), which support delivery of short messages on Traffic Channels. Service Option 6 and Service Option 14 conform to the general requirements for service options specified in [10].

A mobile station can obtain Short Message Service operating in either the analog or the spread spectrum (CDMA) mode when it conforms to this standard. This standard does not address the quality or reliability of Short Message Service, nor does it cover equipment performance or measurement procedures.

SECTION SUMMARY

1. **Introduction.** This section defines the terms, references, protocols and network reference model used in this document.
2. **SMS Relay Layer.** This section defines the requirements for the lower layer of the SMS bearer service protocols. The SMS Relay Layer provides the interface between the Transport Layer and the Link Layer used for message transmission.
3. **SMS Transport Layer.** This section defines the requirements for the upper layer of the SMS bearer service protocols. The SMS Transport Layer manages the end-to-end delivery of messages.
4. **SMS Teleservice Layer.** This section defines the requirements for the SMS Teleservice Layer, which provides application-level data formats and procedures.

NOTES

1. The following verbal forms are used: “Shall” and “shall not” identify requirements to be followed strictly to conform to the standard and from which no deviation is permitted. “Should” and “should not” indicate that one of several possibilities is recommended as particularly suitable, without mentioning or excluding others; that a certain course of action is preferred but not necessarily required; or that (in the negative form) a certain possibility or course of action is discouraged but not prohibited. “May” and “need not” indicate a course of action permissible within the limits of the standard. “Can” and “cannot” are used for statements of possibility and capability, whether material, physical, or causal.
2. Footnotes appear at various points in this specification to elaborate and to further clarify items discussed in the body of the specification.
3. Unless indicated otherwise, this document presents numbers in decimal form.

Binary numbers are distinguished in the text by the use of single quotation marks. In some tables, binary values may appear without single quotation marks if table notation clearly specifies that values are binary. The character ‘x’ is used to represent a bit of unspecified value. For example ‘xxx00010’ represents any 8-bit binary value such that the least significant five bits equal ‘00010’.

Hexadecimal numbers (base 16) are distinguished in the text by use of the form 0xh.h where h.h represents a string of hexadecimal digits. For example, 0x2fa1 represents a number whose binary value is ‘0010111110100001’ and whose decimal value is 12193. Note that the exact number of bits in the binary representation of a hexadecimal number strictly depends upon the implementation requirements for the variable being represented.
4. “Base station” refers to the functions performed on the fixed network, which are typically distributed among a cell, a sector of a cell, and a mobile communications switching center.

TABLE OF CONTENTS

SECTION SUMMARY.....	iii
NOTES.....	iv
1 Introduction	1-1
1.1 General Description	1-1
1.2 Terms	1-3
1.3 References	1-5
1.4 Network Reference Model.....	1-7
1.5 SMS Protocols.....	1-8
2 SMS Relay Layer	2-1
2.1 Introduction	2-1
2.2 Overview.....	2-1
2.2.1 Model of Operation	2-1
2.2.1.1 U _m Interface	2-1
2.2.1.2 N (Intersystem) Interface.....	2-2
2.2.2 Relay Layer Functions	2-2
2.2.3 Service Description.....	2-3
2.2.3.1 Service Primitives.....	2-3
2.2.3.1.1 U _m Interface Primitives.....	2-5
2.2.3.1.2 N Interface Primitives.....	2-6
2.2.3.2 Services Provided by the Relay Layer	2-7
2.2.3.2.1 Point-to-Point.....	2-7
2.2.3.2.2 Broadcast	2-7
2.2.3.3 Services Required from Protocol Layers.....	2-7
2.2.3.4 Services Required from Intersystem Links	2-8
2.3 Elements of Procedures	2-8
2.3.1 Formats of Fields	2-8
2.3.2 Error Codes	2-8
2.4 Definition of Procedures.....	2-9
2.4.1 Mobile Station Procedures	2-9
2.4.1.1 Point-to-Point Procedures	2-9
2.4.1.1.1 Common Channel Procedures.....	2-9

2.4.1.1.1.1	Mobile SMS Message Termination.....	2-9
2.4.1.1.1.2	Mobile SMS Message Origination.....	2-9
2.4.1.1.2	Mobile Station Traffic Channel Procedures.....	2-11
2.4.1.1.2.1	Negotiation for the SMS Service Option.....	2-11
2.4.1.1.2.1.1	Procedures Using Service Option Negotiation.....	2-11
2.4.1.1.2.1.2	Procedures Using Service Negotiation.....	2-12
2.4.1.1.2.2	Mobile SMS Message Termination.....	2-13
2.4.1.1.2.3	Traffic Channel Setup.....	2-14
2.4.1.1.2.4	Mobile Station Message Origination in the Conversation Substate.....	2-14
2.4.1.2	Broadcast Procedures.....	2-15
2.4.1.2.1	Common Channel Procedures for Broadcast SMS.....	2-15
2.4.1.2.2	Traffic Channel Procedures.....	2-16
2.4.2	Base Station Procedures, U _m Interface.....	2-16
2.4.2.1	Point-to-Point Procedures.....	2-16
2.4.2.1.1	Common Channel Procedures.....	2-16
2.4.2.1.1.1	Mobile SMS Message Origination.....	2-16
2.4.2.1.1.2	Mobile SMS Message Termination.....	2-17
2.4.2.1.2	Base Station Traffic Channel Procedures.....	2-18
2.4.2.1.2.1	Negotiation for the SMS Service Option.....	2-18
2.4.2.1.2.1.1	Procedures Using Service Option Negotiation.....	2-18
2.4.2.1.2.1.2	Procedures Using Service Negotiation.....	2-19
2.4.2.1.2.2	Mobile SMS Message Origination.....	2-19
2.4.2.1.2.3	Traffic Channel Setup.....	2-20
2.4.2.1.2.4	Mobile Station Message Termination in the <i>Conversation Substate</i>	2-20
2.4.2.2	Broadcast Procedures.....	2-21
2.4.3	Base Station Procedures, N Interface.....	2-22
3	SMS Transport Layer.....	3-1
3.1	Introduction.....	3-1
3.2	Overview.....	3-1
3.2.1	Model of Operation.....	3-1
3.2.2	Transport Layer Functions.....	3-1
3.2.2.1	Bearer Service End Points.....	3-1

3.2.2.2	Bearer Service Relay Points.....	3-1
3.2.3	Service Description.....	3-2
3.2.3.1	Teleservice Interface	3-2
3.2.3.2	Services Required from the Relay Layer	3-2
3.3	Definition of Procedures.....	3-2
3.3.1	Relay Point Procedures, Base Station	3-2
3.3.2	End Point Procedures, Mobile Station.....	3-5
3.3.3	Authentication Procedures	3-6
3.3.3.1	Mobile Station Procedures	3-6
3.3.3.2	Base Station Procedures	3-6
3.4	Transport Layer Messages	3-7
3.4.1	Message Format	3-7
3.4.2	Message Definitions.....	3-8
3.4.2.1	SMS Point-to-Point Message	3-8
3.4.2.2	SMS Broadcast Message	3-8
3.4.2.3	SMS Acknowledge Message.....	3-9
3.4.3	Parameter Definitions	3-9
3.4.3.1	Teleservice Identifier	3-10
3.4.3.2	Service Category	3-11
3.4.3.3	Address Parameters	3-12
3.4.3.4	Subaddress.....	3-15
3.4.3.5	Bearer Reply Option.....	3-17
3.4.3.6	Cause Codes.....	3-18
3.4.3.7	Bearer Data	3-19
4	SMS Teleservice Layer	4-1
4.1	Introduction	4-1
4.2	Overview.....	4-1
4.3	Teleservice Procedures.....	4-1
4.3.1	General.....	4-1
4.3.1.1	Mobile Station Message Termination.....	4-1
4.3.1.2	Mobile Station Message Origination	4-2
4.3.1.3	Broadcast Messaging Service	4-2

4.3.1.4	Analog Mode SMS Services.....	4-2
4.3.1.4.1	Extended Protocol SMS Services.....	4-3
4.3.1.4.2	Alert With Info SMS Services	4-4
4.3.1.5	Setting of Message Identifier Field	4-5
4.3.1.6	Unique Message Identification.....	4-5
4.3.2	IS-91 Extended Protocol Enhanced Services	4-6
4.3.3	Wireless Paging Teleservice (WPT)	4-6
4.3.4	Wireless Messaging Teleservice (WMT)	4-8
4.3.5	Voice Mail Notification (VMN)	4-11
4.3.5.1	Enhanced Voice Mail Notification	4-11
4.3.6	Wireless Application Protocol (WAP)	4-13
4.3.7	Wireless Enhanced Messaging Teleservice (WEMT).....	4-13
4.3.8	Service Category Programming Teleservice (SCPT).....	4-16
4.3.9	Card Application Toolkit Protocol Teleservice (CATPT)	4-17
4.4	Teleservice Message Contents	4-18
4.4.1	SMS Deliver Message	4-18
4.4.2	SMS Submit Message.....	4-19
4.4.3	SMS Cancellation Message.....	4-20
4.4.4	SMS User Acknowledgment Message	4-20
4.4.5	SMS Delivery Acknowledgment Message	4-21
4.4.6	SMS Read Acknowledgment Message	4-21
4.4.7	SMS Deliver Report Message	4-21
4.4.8	SMS Submit Report Message	4-22
4.5	Bearer Data Subparameters.....	4-23
4.5.1	Message Identifier	4-24
4.5.2	User Data	4-26
4.5.3	User Response Code	4-28
4.5.4	Message Center Time Stamp	4-29
4.5.5	Validity Period - Absolute.....	4-31
4.5.6	Validity Period - Relative	4-33
4.5.7	Deferred Delivery Time - Absolute	4-35
4.5.8	Deferred Delivery Time - Relative	4-37

4.5.9	Priority Indicator	4-38
4.5.10	Privacy Indicator.....	4-39
4.5.11	Reply Option.....	4-40
4.5.12	Number of Messages.....	4-42
4.5.13	Alert on Message Delivery	4-43
4.5.14	Language Indicator	4-44
4.5.15	Call-Back Number	4-45
4.5.16	Message Display Mode.....	4-47
4.5.17	Multiple Encoding User Data	4-48
4.5.18	Message Deposit Index	4-50
4.5.19	Service Category Program Data.....	4-51
4.5.20	Service Category Program Results.....	4-55
4.5.21	Message Status.....	4-57
4.5.22	TP-Failure Cause.....	4-59
4.5.23	Enhanced VMN	4-60
4.5.24	Enhanced VMN Ack.....	4-66
A	ANNEX A Enhanced Voice Mail Notification DTMF Commands	A-1
A.1	Connection to the Voice Mail System	A-1
A.2	Enhanced Voice Mail Notification DTMF Commands.....	A-1
A.2.1	Set Voice Mail Message ID	A-14-1
A.2.2	Delete Multiple Messages.....	A-24-1
A.2.3	Play	A-24-1
A.2.4	Pause Playback.....	A-24-1
A.2.5	Resume Playback	A-24-1
A.2.6	Skip Forward.....	A-24-1
A.2.7	Skip Backward	A-34-1
A.2.8	Delete Message	A-34-1
A.2.9	Reply to Message	A-34-1
A.2.10	Play Active Greeting.....	A-34-1
A.2.11	Record Active Greeting.....	A-34-1
A.2.12	Play Name	A-34-1
A.2.13	Record Name	A-44-1

A.2.14 Set PasswordA-44-1

LIST OF FIGURES

Figure 1.4-1. Simplified SMS Reference Model 1-7
Figure 1.5-1. SMS Protocol Stack..... 1-8
Figure 2.2.3.1-1. Primitive Types 2-3

LIST OF TABLES

Table 2.2.3.1-1. U _m Interface Primitive Types	2-4
Table 2.2.3.1-2. U _m Interface Primitives.....	2-4
Table 2.2.3.1.1-1. Relay Layer Service Primitives, U _m Interface.....	2-5
Table 2.2.3.1.1-2. RL-DATA Primitive Parameters, U _m Interface.....	2-5
Table 2.2.3.1.2-1. Relay Layer Service Primitives, N Interface.....	2-6
Table 2.4.1.1.2.1.2-1. Valid Service Configuration Attributes for Service Option 6.....	2-13
Table 2.4.1.1.2.1.2-2. Valid Service Configuration Attributes for Service Option 14.....	2-13
Table 3.4-1. SMS Transport Layer Messages	3-7
Table 3.4.2.1-1. SMS Point-to-Point Message Parameters.....	3-8
Table 3.4.2.2-1. SMS Broadcast Message Parameters.....	3-8
Table 3.4.2.3-1. SMS Acknowledge Message Parameters	3-9
Table 3.4.3-1. Parameter Identifiers	3-9
Table 3.4.3.1-1. Supported Teleservices	3-10
Table 3.4.3.3-1. Data Network Address Number Types	3-13
Table 3.4.3.4-1. Subaddress Type Values.....	3-16
Table 4.3.1.3-1. SMS Deliver Message Subparameters, Broadcast Messaging Service.....	4-2
Table 4.3.1.4.1-1. Bearer Data Subparameters for Extended Protocol Messages.....	4-3
Table 4.3.2-1. SMS Deliver Message Subparameters, CMT-91	4-6
Table 4.3.3-1. SMS Deliver Message Subparameters, WPT	4-7
Table 4.3.3-2. SMS Submit Message Subparameters, WPT.....	4-7
Table 4.3.4-1. SMS Deliver Message Subparameters, WMT	4-9
Table 4.3.4-2. SMS Submit Message Subparameters, WMT.....	4-10
Table 4.3.5-1. SMS Deliver Message Subparameters, VMN.....	4-11
Table 4.3.6-1. SMS Deliver Message Subparameters, WAP	4-13
Table 4.3.6-2. SMS Submit Message Subparameters, WAP.....	4-13
Table 4.3.7-1 SMS Deliver Message Subparameters, WEMT	4-14
Table 4.3.7-2. SMS Submit Message Subparameters, WEMT.....	4-15
Table 4.3.8-1. SMS Deliver Message Subparameters, SCPT	4-16
Table 4.3.8-2. SMS Submit Message Subparameters, SCPT	4-16
Table 4.3.9-1. SMS Deliver Message Subparameters, CATPT.....	4-17
Table 4.3.9-2. SMS Submit Message Subparameters, CATPT	4-17

Table 4.3.9-3. SMS User Acknowledgment Message Subparameters, CATPT 4-17

Table 4.4.1-1. SMS Deliver Message Subparameters 4-18

Table 4.4.2-1. SMS Submit Message Subparameters 4-19

Table 4.4.3-1. SMS Cancellation Message Subparameters 4-20

Table 4.4.4-1. SMS User Acknowledgment Message Subparameters 4-20

Table 4.4.5-1. SMS Delivery Acknowledgment Message Subparameters 4-21

Table 4.4.6-1. SMS Read Acknowledgment Message Subparameters 4-21

Table 4.4.7-1. SMS Deliver Report Message Subparameters 4-22

Table 4.4.8-1. SMS Submit Report Message Subparameters 4-22

Table 4.5-1. Bearer Data Subparameter Identifiers 4-23

Table 4.5.1-1. Message Types 4-25

Table 4.5.6-1. Coding of Relative Time Fields 4-34

Table 4.5.9-1. Priority Indicator Values 4-38

Table 4.5.10-1. Privacy Indicator Values 4-39

Table 4.5.13-1. ALERT_PRIORITY Values 4-43

Table 4.5.16-1. Message Display Mode Indicator Values 4-47

Table 4.5.19-1. ALERT_OPTION Values 4-53

Table 4.5.20-1. Service Category Program Result Codes 4-56

Table 4.5.21-1. SMS Message Status Codes 4-58

Table A.2-1. Enhanced Voice Mail Notification DTMF Commands A-1

1 INTRODUCTION

1.1 General Description

The Short Message Service (SMS) allows the exchange of short messages between a mobile station and the wireless system, and between the wireless system and an external device capable of transmitting and optionally receiving short messages. The external device may be a voice telephone, a data terminal or a short message entry system.

The Short Message Service consists of message entry features, administration features, and message transmission capabilities. These features are distributed between a wireless system and the SMS message center (MC) that together make up the SMS system. The message center may be either separate from or physically integrated into the wireless system.

Short message entry features are provided through interfaces to the message center and the mobile station. Senders use these interfaces to enter short messages, intended destination addresses, and various delivery options.

Message center interfaces may include features such as audio response prompts and DTMF reception for dial-in access from voice telephones, as well as appropriate menus and message entry protocols for dial-in or dedicated data terminal access. Mobile station interfaces may include keyboard and display features to support message entry. Additionally, a wireless voice service subscriber can use normal voice or data features of the mobile station to call an SMS system to enter a message.

An SMS Teleservice can provide the option of specifying priority level, future delivery time, message expiration interval, or one or more of a series of short, pre-defined messages.

If supported by the Teleservice, the sender can request acknowledgment that the message was received by the mobile station. An SMS recipient, after receiving a short message, can manually acknowledge the message. Optionally, the recipient can specify one of a number of pre-defined messages to be returned with the acknowledgment to the sender.

SMS administration features include message storage, profile editing, verification of receipt, and status inquiry capabilities. SMS administration is not within the scope of this standard.

The SMS transmission capabilities provide for the transmission of short messages to or from an intended mobile station, and the return of acknowledgments and error messages. These messages and acknowledgments are transmitted to or from the mobile station whether it is idle or engaged in a voice or data call.

The wireless service provider may offer SMS transmission to its wireless voice and data customers only, or may provide an SMS-only service without additional voice or data transmission capabilities.

This standard also provides for the broadcast of messages. All available mobile stations on a Paging Channel or Primary Broadcast Control Channel can receive a broadcast message. A broadcast message is not acknowledged by the mobile station. Broadcast Messaging

- 1 Services may be made available to mobile stations on a Paging Channel or Primary
- 2 Broadcast Control Channel as well as mobile stations in a call on a Traffic Channel.
- 3

1.2 Terms

AFI. Authority and Format Identifier (AFI). The high order octet of the NSAP-Address.

Base Station. A fixed station that is used for communicating with mobile stations. Depending upon the context, the term base station may refer to a cell, a sector, an MSC, or another part of the wireless system. See also MSC.

Bearer Service. The portion of the SMS system responsible for delivery of messages between the message center and mobile user equipment. In this standard, the bearer service protocol is divided into a Transport Layer and a Relay Layer.

Broadcast. The bearer layer mechanism that is used to deliver SMS messages on the Paging Channel, Primary Broadcast Control Channel, or on the Forward Traffic Channel to all available mobile stations.

Broadcast Messaging Service. A teleservice that allows an SMS message to be sent to all mobile stations.

CATPT. Card Application Toolkit Protocol Teleservice (CATPT) that is used for data download to the R-UIM via SMS.

CMT. Cellular Messaging Teleservice. See also Wireless Messaging Teleservice.

CPT. Cellular Paging Teleservice. See also Wireless Paging Teleservice.

EMS. Enhanced Messaging Service. This service is further described in [21].

End Point. An element of the SMS delivery system that can originate or terminate SMS messages.

IWF. An interworking function provides information conversion. A data service IWF provides functions needed for a mobile station to communicate with data terminal equipment connected to the network.

MC. SMS Message Center.

Mobile Equipment (ME). An R-UIM capable mobile station without an R-UIM inserted.

Mobile Switching Center (MSC). A configuration of equipment that provides wireless radio telephone service. Also called Mobile Telephone Switching Office (MTSO).

Mobile-Originated. Submitted to an SMS service provider by a mobile station.

Mobile Station. A station, fixed or mobile, which serves as the end user's wireless communication link with the base station. Mobile stations include portable units (e.g., hand-held mobile units) and units installed in vehicles.

Mobile-Terminated. Delivered to a mobile station by an SMS service provider.

NSAP. Network Service Access Point (NSAP). The NSAP is an abstraction of a point where the Network Layer service user and the Network Layer service provider meet. Each Network Entity may be accessed through one or more NSAPs by its users. Each NSAP has one or more NSAP-Addresses.

Removable User Identity Module (R-UIM). See User Identity Module.

1 **Relay Layer.** The layer of the bearer service protocol responsible for the interface between
2 the Transport Layer and the Link Layer used for message transmission.

3 **Relay Point.** An element of the SMS delivery system that forwards SMS messages.

4 **SCPT.** Service Category Programming Teleservice (SCPT) that is used to add or remove
5 Broadcast Service Categories in the mobile station profile.

6 **SMS.** Short Message Service.

7 **STX.** One of several allowable character sets allowed in [14] for CHAR. An STX ('111100')
8 may be placed in the message to link this message to the previous message sent. All
9 values other than STX in the 15th character position indicate end of message and are not
10 displayed. The STX character is only valid for Short Messages.

11 **TE.** Terminal Equipment.

12 **Teleservice Layer.** The protocol layer providing the end-to-end SMS application.

13 **Transport Layer.** The layer of the bearer service protocol responsible for the end-to-end
14 delivery of messages.

15 **User Identity Module (UIM).** The UIM contains subscription information such as the NAM
16 and may contain subscription feature information. The UIM can be integrated into any
17 mobile terminal or it may be removable.

18 **Universal Coordinated Time (UTC).** An internationally agreed-upon time scale
19 maintained by the Bureau International de l'Heure (BIH) used as the time reference by
20 nearly all commonly available time and frequency distribution systems (i.e., WWV, WWVH,
21 LORAN-C, Transit, Omega, and GPS).

22 **VMN.** Voice Mail Notification. VMN is a Teleservice supported by [8]. This Teleservice is
23 an extension of the Voice Mail Status capability defined in [14].

24 **WAP.** Wireless Application Protocol.

25 **WEMT.** Wireless Enhanced Messaging Teleservice (WEMT) that is used to carry Enhanced
26 Messaging Service (EMS) over SMS.

27 **WMT.** Wireless Messaging Teleservice. This Teleservice is further described in [11]. WMT
28 is a point-to-point service only.

29 **WPT.** Wireless Paging Teleservice. This Teleservice is further described in [11]. WPT is a
30 point-to-point service only.

31

1.3 References

The following standards are referenced in this text. At the time of publication, the editions indicated were valid. All standards are subject to revision, and parties to agreements based on this standard are encouraged to investigate the possibility of applying the most recent editions of the standards indicated below. ANSI and TIA maintain registers of currently valid national standards published by them.

Normative References

1. **ISO 646:1983**, *Information Processing - Seven Byte Character Set for Information Processing Character Interchange*.
2. **ISO 8348:1987 AD2**, *Information Processing Systems - Data Communications - Network Service Definition, Addendum 2: Network Layer Addressing*.
3. **ITU-T Recommendation T.50**, *International Reference Alphabet (IRA) (Formerly International Alphabet No. 5 or IA5) - Information technology - 7-bit coded character set for information interchange*.
4. **ITU-T Recommendation X.213**, *Information technology - Open Systems Interconnection - Network service definition*.
5. **ITU-T Recommendation X.25**, *Interface between Data Terminal Equipment (DTE) and Data Circuit-terminating Equipment (DCE) for terminals operating in the packet mode and connected to public data networks by dedicated circuit*.
6. **ANSI T1.607-2000(R2004)1990**, *Integrated Services Digital Network (ISDN) - Layer 3 Signaling Specification for Circuit Switched Bearer Service for Digital Subscriber Signaling System Number 1 (DSS1)*.
7. **~~ANSI INCITS 4-1986 (R2002)~~**, *~~Information Systems - Coded Character Sets - 7-Bit American National Standard Code for Information Interchange (7-Bit ASCII)~~*. **~~ANSI X3.4-1986~~**, *~~Code for Information Interechange~~*.
8. **N.S0005**, *Cellular Radiotelecommunications Intersystem Operations*.
9. **C.S0004-D**, *Signaling Link Access Control (LAC) Standard for cdma2000 Spread Spectrum Systems*.
10. **C.S0005-D**, *Upper Layer (Layer 3) Signaling Standard for cdma2000 Spread Spectrum Systems*.
11. **S.R0006**, *Cellular Features Description*.
12. **TIA/EIA-691**, *Mobile Station - Base Station Compatibility Standard for Enhanced 800 MHz Analog Cellular (ANSI/TIA/EIA-691-99)*. October, 1999.
13. **TIA/EIA-553-A**, *Mobile Station - Base Station Compatibility Standard (ANSI TIA/EIA-553-A-99)*. October, 1999.
14. **TIA/EIA/IS-91-A**, *Base Station - Mobile Station Compatibility Specification for 800 MHz Cellular, Auxiliary, and Residential Services (1999)*. November, 1999.

C.S0015-B v1.22.010

~~15. C.R1001-D, Administration of Parameter Value Assignments for cdma2000® Spread Spectrum Standards. April, 2003.~~

16. Internet Engineering Task Force (IETF) RFC 791, Internet Protocol.

17. IETF RFC 822, Standard for the Format of ARPA Internet Text Messages.

~~18. WAP-210-WAPArch-20010712-a, Wireless Application Protocol Architecture Specification.~~

19. C.S0023-B, Removable User Identity Module [R-UIM] for Spread Spectrum Systems.

20. 3GPP TS 23.038, Alphabets and Language-Specific Information.

21. 3GPP TS 23.040, Technical Realization of the Short Message Service (SMS).

22. TIA/EIA-95-B, Mobile Station-Base Station Compatibility Standard for Dual-Mode Spread Spectrum Systems.

~~23. S.R0005-B, Network Reference Model for cdma2000 Spread Spectrum Systems. April, 2001.~~

~~24. WAP-259-WDP-20010614-a, Wireless Datagram Protocol (WDP).~~

25. C.S0035, CDMA Card Application Toolkit (CCAT). October, 2002.

Informative References

15. C.R1001-D, Administration of Parameter Value Assignments for cdma2000® Spread Spectrum Standards. April, 2003.

18. WAP-210-WAPArch-20010712-a, Wireless Application Protocol Architecture Specification.

23. S.R0005-B, Network Reference Model for cdma2000 Spread Spectrum Systems. April, 2001.

24. WAP-259-WDP-20010614-a, Wireless Datagram Protocol (WDP).

1.4 Network Reference Model

Figure 1.4-1 contains the network reference model for SMS. This model presents functional entities and associated interface reference points that may logically comprise a wireless network. The interface reference points identified in Figure 1.4-1 are a subset of the reference points defined in [23], [8]. The model is intended to provide a level of abstraction that facilitates the specification of messages within this standard. As such, implementations may vary with respect to how the functional entities are distributed among physical units.

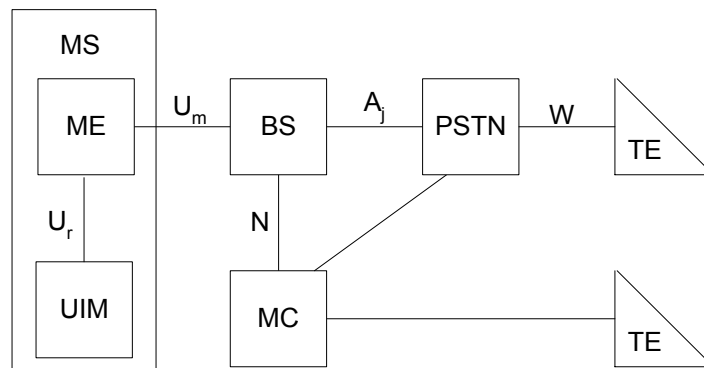

Figure 1.4-1. Simplified SMS Reference Model

The base station (BS) in this model contains the transceiver equipment, Mobile Switching Center (MSC) and any Inter-Working Function (IWF) required for network connection. These elements are grouped together because there is no need to distinguish them in this standard.

The message center element in this model represents a generic SMS Message Center function. The N reference point represents one or more standardized interfaces between an SMS message center and a BS. The Terminal Equipment (TE) is voice or data equipment connected either directly or indirectly to the message center.

It is possible for the message center to be included in, or co-located with, a base station. In this case, the N Interface is internal to the base station. For purposes of this standard, the procedures defined for the N Interface should be followed for such internal interfaces.

1.5 SMS Protocols

The SMS protocol stack for the CDMA mode of operation is illustrated in Figure 1.5-1. Shaded areas indicate the protocol elements covered in this standard.

In the analog mode of operation, only the Teleservice Layer portion of this standard applies (see 4.3.1.4).

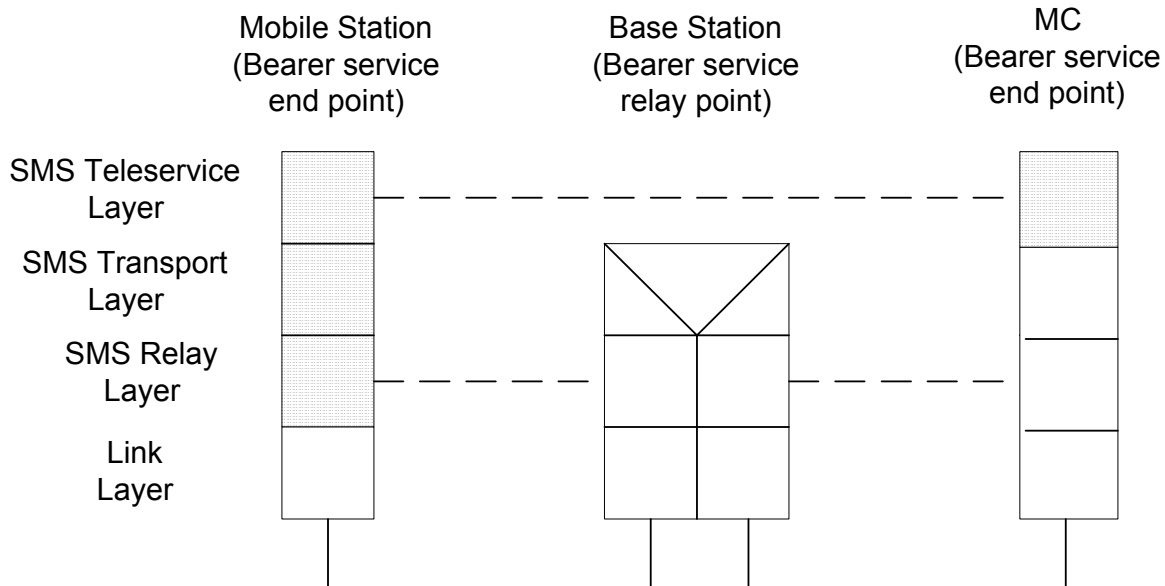

Figure 1.5-1. SMS Protocol Stack

Figure 1.5-1 shows a simplified view of the network carrying SMS, including only a single SMS message relay point. In principle any number of relay points could be included, each containing an SMS protocol stack similar to that shown for the base station. For example, during a call that has undergone an intersystem handoff, SMS messages arriving at the mobile station's anchor base station are forwarded to the current serving base station for delivery.

The SMS bearer service is the portion of the SMS system responsible for delivery of messages between the message center and mobile user equipment. The bearer service is provided by the SMS Transport Layer and the SMS Relay Layer.

The SMS Transport Layer is the highest layer of the bearer service protocol. The Transport Layer manages the end-to-end delivery of messages. In an entity serving as a relay point, the Transport Layer is responsible for receiving SMS Transport Layer messages from an underlying SMS Relay Layer, interpreting the destination address and other routing information, and forwarding the message via an underlying SMS Relay Layer. In entities serving as end points, the Transport Layer provides the interface between the SMS Bearer Service and the SMS Teleservice.

The SMS Relay Layer provides the interface between the Transport Layer and the Link Layer used for message transmission.

2 SMS RELAY LAYER

2.1 Introduction

The SMS Relay Layer provides the interface between the SMS Transport Layer and the Link Layer used to carry short message traffic. This standard addresses the SMS Relay Layer in mobile stations and base stations and their interfaces to the Link Layers for the U_m and N reference points.

On the U_m Interface, the SMS Relay Layer supports the SMS Transport Layer by providing the interface to the transmission protocols defined in either [10] or [22] that are needed to carry SMS data between CDMA mobile stations and base stations. Specific requirements are given for operation with a U_m Interface Link Layer that is compliant with [10]; however, these requirements also apply to a U_m Interface Link Layer that is compliant with [22] (where appropriate).

On the N Interface, the SMS Relay Layer supports the SMS Transport Layer by providing the interface to the network protocols needed to carry SMS data between the message center and base stations. For the general N Interface, the SMS Relay Layer requirements in this standard are limited to the requirements for the Relay Layer interface to the Transport Layer. Specific requirements are given for operation with an N Interface that is part of a network compliant with [8].

2.2 Overview

2.2.1 Model of Operation

2.2.1.1 U_m Interface

In this standard, the U_m reference point is the CDMA wireless system as described in [10]. The dual-mode CDMA wireless system provides analog and digital mobile telephone service using the wireless mobile telephone frequency bands. Requirements for SMS message delivery in the analog mode are found in [10].

The CDMA system provides the functions necessary for a mobile station to acquire CDMA system timing and the overhead information needed for access to system functions. A CDMA mobile station that is fully initialized and is capable of providing access to system functions can operate in any of the following three states that are defined in [10]:

- *Mobile Station Idle State*
- *System Access State*
- *Mobile Station Control on the Traffic Channel State*

The SMS Relay Layer can deliver messages to mobile stations in any of these states. The Relay Layer is also capable of using call control signaling to direct mobile stations to change states as necessary in order to deliver SMS messages.

1 2.2.1.2 N (Intersystem) Interface

2 In this standard, the N reference point is assumed to be an intersystem network link with
3 connectivity to the message center. Intersystem links can use a variety of public and
4 private protocols, one example of which is defined in [8].

5 SMS protocols and message formats on intersystem links may differ from those used on the
6 CDMA air interface. The N Interface Relay Layer is responsible for formatting and parsing
7 SMS messages as necessary when transmitting and receiving messages on the intersystem
8 links.

9 2.2.2 Relay Layer Functions

10 The Relay Layer performs the following functions:

- 11 • Accepting Transport Layer messages and delivering them to the next indicated relay
12 point or end point.
- 13 • Providing error indications to the Transport Layer when messages cannot be
14 delivered to the next relay point or end point.
- 15 • Receiving messages and forwarding them to the Transport Layer.
- 16 • Interfacing to and controlling the Link Layer used for message relay.
- 17 • Formatting messages according to the SMS standards and related message
18 standards, as required by the Link Layer or peer SMS layers.

19

1 2.2.3 Service Description

2 2.2.3.1 Service Primitives

3 Service primitives represent a logical exchange of information between layers. The types of
4 primitives used in the Relay Layer are shown in Figure 2.2.3.1-1.

5

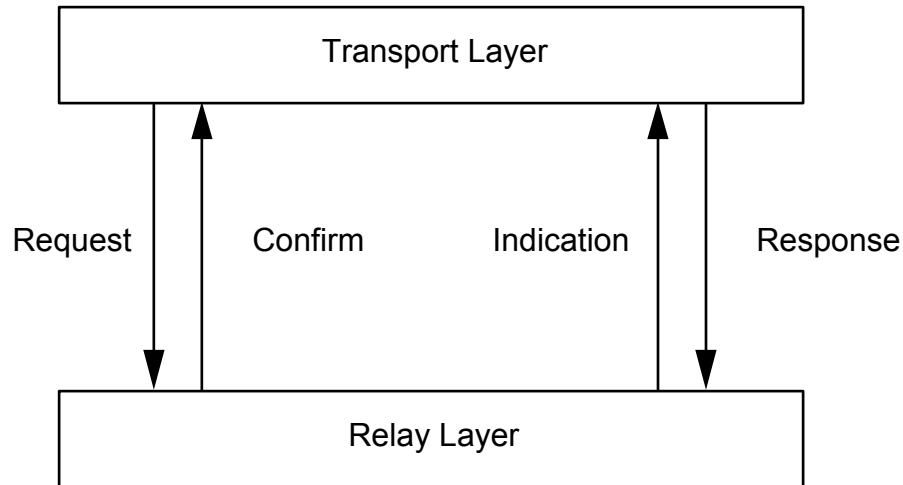

6

7

Figure 2.2.3.1-1. Primitive Types

8 The *Request* primitive type is used by the Transport Layer to request a service from the
9 Relay Layer.

10 The *Confirm* primitive type is used by the Relay Layer to report a consequence of the
11 Request primitive type.

12 The *Indication* primitive type is used by the Relay Layer to provide information to the
13 Transport Layer.

14 The *Response* primitive type is used by the Transport Layer to request a service from the
15 Relay Layer as a consequence of the Indication primitive type.

16 The following tables contain some examples of the primitive definitions. The conventions
17 used for service interface primitives are shown in Table 2.2.3.1-1.

Table 2.2.3.1-1. U_m Interface Primitive Types

Primitive Type	Source	Destination	Purpose
<i>Request</i>	Service user	Service provider	Request a service, resource, etc.
<i>Confirm</i>	Service provider	Service user	Response to a <i>Request</i> primitive
<i>Indication</i>	Service provider	Service user	Indicates that data or an event for the service user has occurred
<i>Response</i>	Service user	Service provider	Acknowledgment of an <i>Indication</i>

Note that every *Request* primitive has a corresponding *Confirm* primitive, and every *Indication* primitive has a corresponding *Response* primitive. The invocation of service primitives is noted as follows:

RX.Primitive_Type(parameters)

where RX, Primitive_Type and parameters are defined in Table 2.2.3.1-2.

Table 2.2.3.1-2. U_m Interface Primitives

<i>RX</i>	An abbreviation for the service provider entity (e.g., RL-BCDATA for Relay Layer Broadcast Data).
<i>Primitive_Type</i>	The specific Primitive Type as defined in Table 2.2.3.1-1 (e.g., <i>Request</i>)
<i>Parameters</i>	An (optional) list of parameters for the primitive (e.g., Address)

For example, a request to transfer broadcast SMS messages between the Transport Layer and the Relay Layer uses the RL-BCDATA primitive. The Relay Layer passes the Transport Layer Message text, and the destination broadcast address parameters as follows:

RL-BCDATA.Request(Transport Layer Message, Broadcast Address)

Primitives and parameters for the U_m Interface Relay Layer are summarized in Table 2.2.3.1.1-1.

2.2.3.1.1 U_m Interface Primitives

Table 2.2.3.1.1-1 summarizes the primitives supported by the Relay Layer for the U_m Interface.

Table 2.2.3.1.1-1. Relay Layer Service Primitives, U_m Interface

Name	Type				Parameters
	Request	Confirm	Indication	Response	
RL-DATA	X	X	X	X	Transport Layer Message, Address, Authentication, Confirm Request
RL-BCDATA	X		X		Transport Layer Message, Broadcast Address
RL-ERROR			X		Error Type
RL-CONTROL	X				

The RL-DATA primitive is used to transfer point-to-point SMS messages and SMS acknowledgments between the Transport Layer and the Relay Layer. The parameters of the RL-DATA primitive are the Transport Layer message text, authentication data, confirmation request and the mobile station identifier, which may be a source or destination address, according to the direction of transmission. For the mobile station and base station U_m Interface Relay Layer, the parameters of the RL-DATA primitive are summarized in Table 2.2.3.1.1-2.

Table 2.2.3.1.1-2. RL-DATA Primitive Parameters, U_m Interface

SMS Entity	Primitive Type	Address	Auth	Conf Req	Text
Mobile	<i>Request</i>	Originating mobile station identifier	X	X	X
	<i>Indication</i>	None			X
	<i>Response</i>	Originating mobile station identifier	X	X	X
Base	<i>Request</i>	Destination mobile station identifier		X	X
	<i>Indication</i>	Originating mobile station identifier	X		X

In the mobile station, the Authentication parameter of the RL-DATA.Request primitive contains the authentication digits used in forming the AUTHR field that is sent in all *Data*

1 *Burst Messages* carrying SMS messages, as required in 3.3.3 and in [9]. In the base
 2 station, the Authentication parameter of the RL-DATA.Request primitive contains the
 3 authentication fields of the received *Data Burst Message*.

4 The RL-BCDATA primitive is used to transfer broadcast SMS messages between the
 5 Transport Layer and the Relay Layer. For the U_m Interface Relay Layer, the parameters of
 6 the RL-BCDATA.Request and RL-BCDATA.Indication primitives are the Transport Layer
 7 message text and the destination broadcast address.

8 The RL-ERROR primitive is used to report Relay Layer errors to the Transport Layer.

9 The RL-CONTROL primitive is used by the Transport Layer to indicate to the Relay Layer
 10 that a Traffic Channel, established solely for carrying SMS data, may be released.

11 2.2.3.1.2 N Interface Primitives

12 Table 2.2.3.1.2-1 summarizes the primitives supported by the Relay Layer for the N
 13 Interface.

14
 15 **Table 2.2.3.1.2-1. Relay Layer Service Primitives, N Interface**

Name	Type				Parameters
	Request	Confirm	Indication	Response	
RL-DATA	X	X	X	X	Transport Layer Message, Address, Confirm Request, Result
RL-BCDATA			X		Transport Layer Message, Service Category, Priority Indicator, Zone Indicator, Language Indicator.
RL-ERROR			X		Error Type

16
 17 The RL-DATA primitive is used to transfer point-to-point SMS messages between the
 18 Transport Layer and the Relay Layer. The parameters of the RL-DATA primitive are the
 19 Transport Layer message text, the destination address, confirmation request and result.

20 The RL-BCDATA primitive is used to transfer broadcast SMS messages from the Relay
 21 Layer to the Transport Layer. The parameters of the RL-BCDATA primitive are the
 22 Transport Layer message text, the Service Category, the Priority Indicator, the Zone
 23 Indicator and the Language Indicator.

24 The RL-ERROR primitive is used to report Relay Layer errors to the Transport Layer. See
 25 2.4.3.

2.2.3.2 Services Provided by the Relay Layer

The U_m Interface Relay Layer provides Transport Layer message delivery between mobile station and base station. The service is provided as a point-to-point service and as a broadcast service.

The N Interface Relay Layer provides message delivery between the base station and the message center. This service is provided as a point-to-point service only.

2.2.3.2.1 Point-to-Point

The point-to-point Relay Layer service provides for the transmission and reception of Transport Layer messages destined for or received from individual mobile stations. When requested, this service provides a confirmation to the Transport Layer that a message sent on the U_m or N Interface was received, based on Link Layer acknowledgment procedures. The primitives used for this service are RL-DATA, RL-ERROR and RL-CONTROL.

For mobile-terminated SMS messages received from the N Interface Link Layer, the base station Relay Layer determines the destination mobile station address and passes the address to the Transport Layer. The Relay Layer may request confirmation of delivery to the mobile station as required by the N Interface Link Layer. For mobile-originated SMS messages received from the Transport Layer, the base station N Interface Relay Layer formats the originating mobile station address, the destination MC address and other information as required by the N Interface Link Layer and passes the message to the N Interface Link Layer.

For mobile-terminated SMS messages received from the Transport Layer, the base station U_m Interface Relay Layer formats the mobile station address and other information as required by the U_m Interface Link Layer and passes the message to the U_m Interface Link Layer. For mobile-originated SMS messages received from the U_m Interface Link Layer, the base station Relay Layer determines the originating mobile station address and passes the address to the Transport Layer.

2.2.3.2.2 Broadcast

The broadcast Relay Layer service provides for the broadcast of Transport Layer messages. For the U_m and N Interfaces, the primitive used for this service is RL-BCDATA.

2.2.3.3 Services Required from Protocol Layers

The Relay Layer for the U_m Interface requires the following services from the protocol layers:

- Transmission of *Data Burst Messages* containing SMS data to or from specific mobile stations.¹ This service includes provision of the location function necessary to deliver messages to a mobile station not on a Traffic Channel.

¹This includes sending a broadcast SMS message to a mobile station on the Traffic Channel.

- 1 • Transmission of *Data Burst Messages* containing SMS data on the Paging Channels,
2 the Forward Common Control Channels or Broadcast Control Channel to a broadcast
3 address.
- 4 • Reception of *Data Burst Messages* containing SMS data on the Access Channels,
5 Enhanced Access Channels, Reverse Common Control Channels, Paging Channels,
6 Forward Common Control Channels, Broadcast Control Channels and Traffic
7 Channels.
- 8 • Notification to mobile stations operating in the slotted mode that broadcast messages
9 will be transmitted.
- 10 • Determination of the current call state of mobile stations.
- 11 • Selection of the type of channel to be used for message delivery.
- 12 • Determination of the maximum message size permitted on the different type of
13 channels.
- 14 • Selection of the Layer 2 acknowledgment option for message delivery.
- 15 • Report of the success or failure of Layer 2 acknowledgment.
- 16 • Report of the success or failure of mobile station paging.
- 17 • Generation of authentication information elements included in the *Data Burst*
18 *Message* according to the requirements of [9] and [10].

19 2.2.3.4 Services Required from Intersystem Links

20 The Relay Layer for the N Interface requires the following services from the intersystem
21 link:

- 22 • Delivery of SMS messages to a message center.
- 23 • Reception of SMS messages from a message center.
- 24 • Report of the success or failure of message delivery.

25 **2.3 Elements of Procedures**

26 2.3.1 Formats of Fields

27 The formats of the parameters passed in Relay Layer service primitives are implementation
28 dependent.

29 2.3.2 Error Codes

30 The error codes used in the RL-ERROR primitive shall be SMS_CauseCode values as
31 defined in the SMS_CauseCode Table in [8].

2.4 Definition of Procedures

2.4.1 Mobile Station Procedures

2.4.1.1 Point-to-Point Procedures

This section defines the procedures for processing of mobile-terminated SMS messages that are addressed to individual mobile stations, and processing of all mobile-originated SMS messages. For mobile-originated SMS messages, the U_m Interface Relay Layer considers all messages to be addressed to the current serving base station. The Transport Layer in the base station is responsible for providing the N Interface address for routing of a mobile-originated message to its final destination.

2.4.1.1.1 Common Channel Procedures

2.4.1.1.1.1 Mobile SMS Message Termination

A mobile station supporting SMS shall accept and process *Data Burst Messages* received while the mobile station is monitoring the Common Channel (see [10]) that are addressed to the mobile station. Processing of Layer 2 fields shall be in accordance with [9].

The SMS Relay Layer shall process all *Data Burst Messages* addressed to the mobile station on the Paging Channel or Forward Common Control Channel and having the BURST_TYPE field set to '000011' (as assigned in [15]). The SMS Relay Layer shall discard the message without further processing if any of the following is true:

- MSG_NUMBER field is set to a value other than 1.
- NUM_MSGS field is set to a value other than 1.
- NUM_FIELDS field is set to zero.

Otherwise, the SMS Relay Layer shall send the Transport Layer an RL-DATA.Indication containing the CHARi fields of the received *Data Burst Message*.

2.4.1.1.1.2 Mobile SMS Message Origination

Mobile-originated SMS messages are received by the mobile station SMS Relay Layer as RL-DATA.Request primitives from the Transport Layer. The requirements of this section apply when an RL-DATA.Request primitive is received from the Transport Layer and the mobile station is in the *Mobile Station Idle State* or *System Access State*.

Mobile stations supporting SMS shall support the *Mobile Station Message Transmission Operation*, as defined in [10]. Mobile stations may allow the user to restrict SMS message origination to Traffic Channels for enhanced message privacy.

When the Relay Layer receives an RL-DATA.Request primitive from the Transport Layer, and the mobile station is in the *Mobile Station Idle State*, the Relay Layer shall determine whether the SMS message can be sent on the reverse Common Channel. As part of this determination, the mobile station should determine whether the SMS message length is such that the message can be sent on the Access Channel, Enhanced Access Channel or

1 Reverse Common Control Channel.² If the SMS message can be sent on the reverse
2 Common Channel, the mobile station may form a *Data Burst Message* (see 2.7.1.3.2.3 of
3 [10]), setting BURST_TYPE to '000011', and transmit it on the reverse Common Channel,
4 following the procedures specified in [10]. The mobile station shall set the MSG_NUMBER
5 and NUM_MSGS fields to 1, and shall set the NUM_FIELDS field to the number of octets in
6 the SMS Transport Layer message. The mobile station address fields shall be set using the
7 address parameter supplied by the Transport Layer in the RL-DATA.Request. The
8 authentication fields shall be set as described in 3.3.3.1 using the authentication
9 parameter supplied by the Transport Layer in the RL-DATA.Request.

10 When the Relay Layer receives an RL-DATA.Request primitive from the Transport Layer,
11 and the mobile station is in the *System Access State* other than the *Page Response*
12 *Substate*, the Relay Layer should store the RL-DATA.Request until the mobile station exits
13 the *System Access State*. If the Relay Layer receives an RL-DATA.Request or an RL-
14 DATA.Response primitive from the Transport Layer, and the mobile station is in the *Page*
15 *Response Substate*, the Relay Layer shall store the RL-DATA.Request or the RL-
16 DATA.Response until the mobile station completes the access attempt. If the mobile
17 station enters the *Mobile Station Idle State*, the Relay Layer should process the
18 RL-DATA.Request as if it had been received while in the *Mobile Station Idle State* (see
19 above). If the mobile station enters the *Mobile Station Control on the Traffic Channel State*,
20 the Relay Layer should process the RL-DATA.Request in accordance with the procedures
21 defined in 2.4.1.1.2.4. If the mobile station enters any other state the Relay Layer may
22 discard the RL-DATA.Request. If the mobile station enters an analog mode task, the
23 mobile station shall return an RL-ERROR.Indication to the Transport Layer. The error code
24 value shall be as defined by the implementation.

25 If an SMS message cannot be sent on the reverse Common Channel because it is too long
26 (see above), or because of other implementation dependent criteria,³ the mobile station
27 shall transmit the SMS messages on the Traffic Channel, following the procedures defined
28 in 2.4.1.1.2.3.

29 Messages transmitted on the reverse Common Channel always require a Layer 2
30 acknowledgment. If the access attempt is acknowledged (see [9]), the Relay Layer shall
31 send an RL-DATA.Confirm primitive to the Transport Layer. If the access attempt fails (see
32 [9]), the Relay Layer should send an RL-ERROR.Indication to the Transport Layer. The
33 error code value shall be as defined by the implementation.

²If Access Channel is used, the maximum size depends on the current Access Channel capsule size, as determined from the *Access Parameters Message* broadcast by the base station. If Enhanced Access Channel or Reverse Common Control Channel is used, the maximum size depends on the current Enhanced Access Channel or Reverse Common Control Channel duration, as determined from the *Enhanced Access Parameters Message* broadcast by the base station. It also depends on the mobile station identifier type that would be used in forming the *Data Burst Message* carrying the SMS message.

³For example, the choice to use the reverse Common Channel or a Reverse Traffic Channel when multiple SMS messages are waiting to be transmitted is implementation dependent.

2.4.1.1.2 Mobile Station Traffic Channel Procedures

2.4.1.1.2.1 Negotiation for the SMS Service Option

In the context of this section, a service option is active when the service option is agreed upon by both mobile station and base station (see [10]). A service option is connected when primary traffic data are being processed in accordance with the requirements of the service option. It is possible for a service option to be active without having been connected, but a service option that is not active cannot be connected.

Negotiation for the SMS Service Option is only required when no other service option is connected.

The SMS Service Option described by this standard shall use service option number 6 when using Multiplex Option 1. The SMS Service Option shall use service option number 14 when using Multiplex Option 2.

The mobile station shall negotiate for Service Option 6 using either service option negotiation⁴ (see 2.4.1.1.2.1.1) or service negotiation (see 2.4.1.1.2.1.2).

The mobile station shall negotiate for Service Option 14 using service negotiation (see 2.4.1.1.2.1.2).

2.4.1.1.2.1.1 Procedures Using Service Option Negotiation

The mobile station shall connect Service Option 6 as follows:

- If Service Option 6 is active when the mobile station enters the *Waiting for Mobile Station Answer Substate*, or if Service Option 6 becomes active when the mobile station is already in the *Waiting for Mobile Station Answer Substate*, then the mobile station shall send a *Connect Order* to the base station as a message requiring acknowledgment without waiting for the user to explicitly command the call to be answered. The mobile station shall enter the *Conversation Substate*.
- If Service Option 6 becomes active when the mobile station is not in the *Conversation Substate*, then it shall connect Service Option 6 immediately upon entering the *Conversation Substate*. Otherwise, the mobile station shall connect Service Option 6 at the time it becomes active. The mobile station shall complete connection of Service Option 6 within 200 ms of starting connection.

When Service Option 6 is connected, the Service Option shall discard all primary traffic data bits received from the multiplex sublayer, and the mobile station shall transmit null traffic channel data (see [10]).

The mobile station shall disconnect Service Option 6 if it exits the *Mobile Station Control on the Traffic Channel State* or if any other service option is connected as primary traffic.

⁴ Restrictions on the use of service option negotiation are defined in [10].

1 2.4.1.1.2.1.2 Procedures Using Service Negotiation

2 The mobile station shall perform service negotiation for Service Option 6 or Service Option
3 14 as described in [10]. The negotiated service configuration shall include only valid
4 attributes for the negotiated service option consistent with those specified in Tables
5 2.4.1.1.2.1.2-1 and 2.4.1.1.2.1.2-2.

6

Table 2.4.1.1.2.1.2-1. Valid Service Configuration Attributes for Service Option 6

Service Configuration Attribute	Valid Selections
Forward Multiplex Option	Multiplex Option 1
Reverse Multiplex Option	Multiplex Option 1
Forward Transmission Rates	Rate Set 1 with all four rates enabled
Reverse Transmission Rates	Rate Set 1 with all four rates enabled
Forward Traffic Type	'0000' or '0001', see Table 3.7.5.7-1 of [10]
Reverse Traffic Type	'0000' or '0001', see Table 3.7.5.7-2 of [10]

Table 2.4.1.1.2.1.2-2. Valid Service Configuration Attributes for Service Option 14

Service Configuration Attribute	Valid Selections
Forward Multiplex Option	Multiplex Option 2
Reverse Multiplex Option	Multiplex Option 2
Forward Transmission Rates	Rate Set 2 with all four rates enabled
Reverse Transmission Rates	Rate Set 2 with all four rates enabled
Forward Traffic Type	'0000' or '0001', see Table 3.7.5.7-1 of [10]
Reverse Traffic Type	'0000' or '0001', see Table 3.7.5.7-2 of [10]

If the mobile station accepts a service configuration, as specified in a *Service Connect Message*, *General Handoff Direction Message* or *Universal Handoff Direction Message*, that includes a service option connection using Service Option 6 or Service Option 14, then the service option connection shall become part of the current service configuration at the action time associated with the message. Service Option 6 or Service Option 14 is considered to be connected when the current service configuration includes a service option connection for it.

If Service Option 6 or Service Option 14 is connected when the mobile station enters the *Waiting for Mobile Station Answer Substate*, or Service Option 6 or Service Option 14 becomes connected while the mobile station is in the *Waiting for Mobile Station Answer Substate*, the mobile station shall send a *Connect Order* to the base station as a message requiring acknowledgment without waiting for the user to explicitly command the call to be answered. The mobile station shall enter the *Conversation Substate*.

The mobile station shall not send a *Service Option Control Message* for Service Option 6 or Service Option 14.

2.4.1.1.2.2 Mobile SMS Message Termination

A mobile station supporting SMS shall accept and process *Data Burst Messages* received on the Forward Traffic Channel (see 3.7.3.3.2.4 of [10]). Processing of Layer 2 fields shall be in

1 accordance with [9]. If requested in the ACK_REQ field, Layer 2 acknowledgments shall be
2 returned whether or not message errors are detected by the SMS Relay Layer.

3 The SMS Relay Layer shall process all *Data Burst Messages* addressed to the mobile station
4 on the Forward Traffic Channel and having the BURST_TYPE field set to '000011'. The
5 SMS Relay Layer shall discard the message without further processing if any of the
6 following is true:

- 7 • MSG_NUMBER field is set to a value other than 1.
- 8 • NUM_MSGS field is set to a value other than 1.
- 9 • NUM_FIELDS field is set to zero.

10 Otherwise, the SMS Relay Layer shall send the Transport Layer an RL-DATA.Indication
11 containing the CHARi fields of the received *Data Burst Message*.

12 2.4.1.1.2.3 Traffic Channel Setup

13 When a mobile station in the *Mobile Station Idle State* needs to send SMS data on a Traffic
14 Channel, the following procedures apply:

15 The mobile station shall send an *Origination Message* (see 2.7.1.3.2.4 of [10]) containing no
16 dialed digits and requesting Service Option 6 or Service Option 14. Authentication of the
17 *Origination Message* shall be conducted according to the procedure described in [9]. The
18 mobile station address fields shall be set using the originating address parameter supplied
19 by the Transport Layer in the RL-DATA.Request.

20 Call processing following the transmission of the *Origination Message* shall follow the
21 procedures defined in [10]. When the mobile station enters the *Conversation Substate*, the
22 mobile station may transmit the SMS messages in accordance with the procedures defined
23 in 2.4.1.1.2.4.

24 2.4.1.1.2.4 Mobile Station Message Origination in the Conversation Substate

25 Mobile-originated SMS messages are received by the mobile station SMS Relay Layer as
26 RL-DATA.Request primitives from the Transport Layer. The requirements of this section
27 apply when an RL-DATA.Request primitive is received from the Transport Layer and the
28 mobile station is in the *Conversation Substate* of the *Mobile Station Control on the Traffic*
29 *Channel State*.

30 The mobile station shall compare the originating address parameter, supplied by the
31 Transport Layer in the RL-DATA.Request, to the mobile station address used to establish
32 the Traffic Channel. If the addresses are not the same, the mobile station shall not
33 transmit the SMS message and shall return an RL-ERROR.Indication to the Transport
34 Layer. The error code value is implementation dependent. If the addresses are the same,
35 the mobile station shall send the message using the following procedures:

36 The mobile station shall form a *Data Burst Message* (see 2.7.2.3.2.4 of [10]), setting
37 BURST_TYPE to '000011' and transmit it on the Reverse Traffic Channel. The mobile
38 station shall set the MSG_NUMBER and NUM_MSGS fields to '1', and shall set the
39 NUM_FIELDS field to the number of octets in the SMS Transport Layer message.

1 If the RL-DATA.Request contains the confirmation request parameter, the mobile station
2 shall set the ACK_REQ Layer 2 field to '1'. If the message is acknowledged (see [9]), the
3 Relay Layer shall send an RL-DATA.Confirm primitive to the Transport Layer. If the mobile
4 station declares acknowledgment failure (see [9]), the Relay Layer shall send an
5 RL-ERROR.Indication to the Transport Layer. The error code value is implementation
6 dependent.

7 If the RL-DATA.Request does not contain the confirmation request parameter, the mobile
8 station may send the *Data Burst Message* either with or without Layer 2 acknowledgment.
9 The Relay Layer should not return the RL-DATA.Confirm or the RL-ERROR.Indication for
10 Layer 2 acknowledgment failure.

11 If the only connected service option is Service Option 6 or Service Option 14, the mobile
12 station shall enter the *Release Substate* with a mobile station release indication (see 2.6.4.5
13 of [10]) if the Relay Layer receives an RL-CONTROL.Request primitive from the Transport
14 Layer.⁵

15 If any service option other than Service Option 6 or Service Option 14 is connected, the
16 mobile station shall remain in the *Conversation Substate* after acknowledgment of the *Data
17 Burst Message*.

18 2.4.1.2 Broadcast Procedures

19 This section defines the procedures for the processing of mobile-terminated SMS messages
20 that are addressed to broadcast addresses. SMS messages that are addressed to broadcast
21 addresses can be sent on the Paging Channel or Broadcast Control Channel; these
22 messages can also be sent to individual mobile stations on the Forward Traffic Channel.

23 2.4.1.2.1 Common Channel Procedures for Broadcast SMS

24 A mobile station supporting broadcast SMS shall accept and process *Data Burst Messages*
25 received on the Paging Channel, Forward Common Control Channel or Broadcast Control
26 Channel ([10]) addressed to any broadcast address that the mobile station is configured to
27 receive.

28 Broadcast addresses are contained in the BC_ADDR field of the broadcast address or page
29 record. Broadcast addresses and page records for burst type '000011' are formatted as
30 specified in 3.3.1. The mobile station may be configured to selectively receive broadcast
31 addresses as described below.

32 The mobile station should receive and process the broadcast message or page if all of the
33 following conditions are satisfied:

- 34 • The SERVICE field contains a service category that the mobile station has been
35 configured to receive;

⁵The RL-CONTROL primitive is used by the Transport Layer to inform the Relay Layer that all anticipated replies from the peer Transport Layer have been received, and the Traffic Channel may therefore be released.

- 1 • The LANGUAGE field contains a language indicator that the mobile station has been
2 configured to receive; and
- 3 • The value indicated by the PRIORITY field is equal to or higher than the priority level
4 the mobile station has been configured to receive.

5 Otherwise, the mobile station may discard the broadcast message or page record.

6 The SMS Relay Layer shall process all *Data Burst Messages* on the Paging Channel,
7 Forward Common Control Channel or Broadcast Control Channel that are addressed to a
8 broadcast address that the mobile station is configured to receive and that have the
9 BURST_TYPE field set to '000011'. The SMS Relay Layer shall discard the message without
10 further processing if any of the following is true:

- 11 • MSG_NUMBER field is set to a value other than 1.
- 12 • NUM_MSGS field is set to a value other than 1.
- 13 • NUM_FIELDS field is set to zero.

14 Otherwise, the SMS Relay Layer shall send the Transport Layer an RL-BCDATA.Indication
15 containing the CHARi fields of the received *Data Burst Message*.

16 2.4.1.2.2 Traffic Channel Procedures

17 Since there is no address field in messages sent on the Forward Traffic Channel, broadcast
18 SMS messages are indistinguishable from other SMS messages at the SMS Relay Layer.
19 Mobile station processing of all SMS messages received on the Forward Traffic Channel is
20 as defined in 2.4.1.1.2.2.⁶

21 2.4.2 Base Station Procedures, U_m Interface

22 2.4.2.1 Point-to-Point Procedures

23 This section defines the procedures for the processing of mobile-terminated SMS messages
24 that are addressed to individual mobile stations, and processing of all mobile-originated
25 SMS messages. For mobile-originated SMS messages, the Relay Layer considers all
26 messages to be addressed to the base station. The Transport Layer in the base station is
27 responsible for providing the N Interface address for the routing of a mobile-originated
28 message to its final destination.

29 2.4.2.1.1 Common Channel Procedures

30 2.4.2.1.1.1 Mobile SMS Message Origination

31 A base station supporting SMS shall accept and process *Data Burst Messages* received on
32 the reverse Common Channel (see 2.7.1.3.2.3 of [10]). The processing of Layer 2 fields
33 shall be in accordance with [9]. Layer 2 acknowledgments shall be returned whether or not
34 message errors are detected by the SMS Relay Layer.

⁶The Transport Layer and the Teleservice Layer determine the broadcast nature of the message from the Transport Layer message type (*SMS Broadcast Message*).

1 The SMS Relay Layer shall process all *Data Burst Messages* received on the reverse
2 Common Channel and having the BURST_TYPE field set to '000011'. The SMS Relay Layer
3 shall discard the message without further processing if any of the following is true:

- 4 • MSG_NUMBER field is set to a value other than 1.
- 5 • NUM_MSGS field is set to a value other than 1.
- 6 • NUM_FIELDS field is set to zero.

7 Otherwise, the SMS Relay Layer shall send the Transport Layer an RL-DATA.Indication
8 containing the CHARi fields of the received *Data Burst Message* and the address of the
9 mobile station from which the *Data Burst Message* was received. The mobile station
10 address shall be determined from the MSID field of the *Data Burst Message*. If the
11 AUTH_MODE field of the *Data Burst Message* is not zero, the RL-DATA.Indication shall also
12 contain the authentication parameter, which shall include the authentication fields of the
13 message.

14 2.4.2.1.1.2 Mobile SMS Message Termination

15 SMS messages addressed to individual mobile stations are received by the base station
16 SMS Relay Layer as RL-DATA.Request primitives from the Transport Layer. The
17 requirements of this section apply when an RL-DATA.Request primitive is received from the
18 Transport Layer and the destination mobile station is not on a Traffic Channel.

19 When the base station Relay Layer receives an RL-DATA.Request primitive from the
20 Transport Layer, and the addressed mobile station is not on a Traffic Channel, the Relay
21 Layer shall determine whether the SMS message data length is such that the message can
22 be sent on the Paging Channel or Forward Common Control Channel.⁷ If the SMS message
23 length is suitable, the base station may form a *Data Burst Message* (see 3.7.2.3.2.9 of [10])
24 sent on the Paging Channel or Forward Common Control Channel, setting BURST_TYPE to
25 '000011'. The base station shall set the MSG_NUMBER and NUM_MSGS fields to 1, and
26 shall set the NUM_FIELDS field to the number of characters in the SMS Transport Layer
27 message. The mobile station address fields shall be set using the address parameter
28 supplied by the Transport Layer in the RL-DATA.Request.

29 When an SMS message is to be transmitted on the Paging Channel or Forward Common
30 Control Channel, the base station shall transmit the message following the procedures
31 specified in 3.6.2 of [10]. The base station may transmit the SMS message throughout the
32 area where the mobile is registered. Alternatively, the base station may page the mobile
33 station to determine its location, send the message on the Paging Channel or Forward
34 Common Control Channel corresponding to the Access Channel or Enhanced Access
35 Channel on which the mobile responds, and then send a *Release Order* to the mobile
36 station. The latter procedure may be more efficient for messages sent to mobile stations
37 operating in the slotted mode.

38 If the SMS message length is unsuitable for transmission on the Paging Channel or
39 Forward Common Control Channel because it is too long, or because of other

⁷The maximum size is implementation dependent.

1 implementation dependent criteria,⁸ the base station shall transmit the SMS message on
2 the Traffic Channel, following the procedures defined in 2.4.2.1.2.3.

3 If the RL-DATA.Request contains the confirmation request parameter, the base station
4 should set the ACK_REQ Layer 2 field to '1'. If the message is acknowledged (see [9]), the
5 Relay Layer shall send an RL-DATA.Confirm primitive to the Transport Layer. If the
6 ACK_REQ field is set to '1' and the message is not acknowledged, or cannot be transmitted,
7 the Relay Layer shall send an RL-ERROR.Indication to the Transport Layer with the error
8 code set to the appropriate SMS_CauseCode value as defined in the SMS_CauseCode Table
9 of [8].

10 If the RL-DATA.Request does not contain the confirmation request parameter, the base
11 station may send the *Data Burst Message* either with or without Layer 2 acknowledgment.
12 The Relay Layer should not return the RL-DATA.Confirm or the RL-ERROR.Indication for
13 Layer 2 acknowledgment failure.

14 2.4.2.1.2 Base Station Traffic Channel Procedures

15 2.4.2.1.2.1 Negotiation for the SMS Service Option

16 Negotiation for the SMS Service Option is only required when no other service option is
17 connected.

18 The SMS Service Option described by this standard shall use service option number 6
19 when using Multiplex Option 1. The SMS Service Option shall use service option number
20 14 when using Multiplex Option 2.

21 The base station shall negotiate for Service Option 6 using either service option
22 negotiation⁹ (see 2.4.2.1.2.1.1) or service negotiation (see 2.4.2.1.2.1.2).

23 The base station shall negotiate for Service Option 14 using service negotiation (see
24 2.4.2.1.2.1.2).

25 2.4.2.1.2.1.1 Procedures Using Service Option Negotiation

26 The base station should wait until the action time associated with the most recently
27 transmitted *Service Option Response Order* or *Service Option Request Order* before
28 initializing and connecting Service Option 6.

29 When Service Option 6 is connected, the Service Option shall discard all primary traffic
30 data bits received from the multiplex sublayer, and the base station should transmit null
31 traffic channel data (see 3.1.3.5.2.4 of [10]).

32 The base station should disconnect Service Option 6 when it enters the *Release Substate*,
33 when it connects any other service option as primary traffic, or when it performs a handoff
34 to analog.

⁸For example, the choice to use the forward Common Channel or a Forward Traffic Channel when multiple SMS messages are waiting to be transmitted is implementation dependent.

⁹ Restrictions on the use of service option negotiation are defined in [10].

2.4.2.1.2.1.2 Procedures Using Service Negotiation

The base station shall perform service negotiation for Service Option 6 or Service Option 14 as described in [10]. The negotiated service configuration shall include only valid attributes for the negotiated service option consistent with those specified in Tables 2.4.1.1.2.1.2-1 and 2.4.1.1.2.1.2-2.

If the base station establishes a service configuration, as specified in a *Service Connect Message*, *General Handoff Direction Message* or *Universal Handoff Direction Message*, that includes a service option connection using Service Option 6 or Service Option 14, then the service option connection shall become part of the current service configuration at the action time associated with the message. Service Option 6 or Service Option 14 is considered to be connected when the current service configuration includes a service option connection for it.

The base station shall not send a *Service Option Control Message* for Service Option 6 or Service Option 14.

2.4.2.1.2.2 Mobile SMS Message Origination

For mobile-originated calls with no dialed digits in the *Origination Message*, the base station should complete an authentication Unique Challenge-Response Procedure (see 2.3.12.1.5 of [10]) immediately after assigning the traffic channel. The Unique Challenge-Response Procedure should be completed successfully before SMS messages are sent to the mobile station and before any mobile-originated SMS messages are forwarded to the message center.

A base station supporting SMS shall accept and process *Data Burst Messages* received on the Reverse Traffic Channel (see 2.7.2.3.2.4 of [10]). Processing of Layer 2 fields shall be in accordance with [9]. If requested in the ACK_REQ field, Layer 2 acknowledgments shall be returned whether or not message errors are detected by the SMS Relay Layer.

The SMS Relay Layer shall process all *Data Burst Messages* received on the Reverse Traffic Channel and having the BURST_TYPE field set to '000011'. The SMS Relay Layer shall discard the message without further processing if any of the following is true:

- MSG_NUMBER field is set to a value other than 1.
- NUM_MSGS field is set to a value other than 1.
- NUM_FIELDS field is set to zero.

Otherwise, the SMS Relay Layer shall send the Transport Layer an RL-DATA.Indication containing the CHAR_i fields of the received *Data Burst Message*, the authentication parameter and the address of the mobile station that sent the message. The mobile station address shall be the address used to establish the Traffic Channel.

If the only connected service option is Service Option 6 or Service Option 14, the base station should release the traffic channel when no SMS messages have been received or sent during a period of time which is implementation dependent.

2.4.2.1.2.3 Traffic Channel Setup

When a base station is to send SMS data on a Traffic Channel and the addressed mobile station is not on a Traffic Channel, the following procedures apply:

The mobile station address for paging shall be determined using the address parameter supplied by the Transport Layer in the RL-DATA.Request. If the mobile station cannot be paged, the Relay Layer shall send an RL-ERROR.Indication primitive to the Transport Layer with error code set to the appropriate SMS_CauseCode value as defined in the SMS_CauseCode Table of [8].

Otherwise, the base station shall page the mobile station and establish a Traffic Channel using the procedures defined in 3.6 of [10]. The base station shall request Service Option 6 or Service Option 14. If the mobile station does not respond to paging, the Relay Layer shall send an RL-ERROR.Indication primitive to the Transport Layer with error code set to the appropriate SMS_CauseCode value as defined in the SMS_CauseCode Table of [8].

When the base station enters the *Conversation Substate*, the base station may transmit the SMS messages in accordance with the procedures defined in 2.4.2.1.2.4.

2.4.2.1.2.4 Mobile Station Message Termination in the *Conversation Substate*

SMS messages addressed to individual mobile stations are received by the base station SMS Relay Layer as RL-DATA.Request primitives from the Transport Layer. The requirements of this section shall be followed when an RL-DATA.Request primitive is received from the Transport Layer and the addressed mobile station is in the *Conversation Substate* of the *Mobile Station Control on the Traffic Channel State*. The addressed mobile station shall be determined using the address parameter supplied by the Transport Layer in the RL-DATA.Request.

The base station shall form a *Data Burst Message* (see 3.7.3.3.2.4 of [10]), set BURST_TYPE to '000011', and transmit it on the Forward Traffic Channel. The base station shall set the MSG_NUMBER and NUM_MSGS fields to 1 and the NUM_FIELDS field to the number of characters in the SMS Transport Layer message.

If the RL-DATA.Request contains the confirmation request parameter, the base station should set the ACK_REQ Layer 2 field to '1'. If the message is acknowledged (see [9]), the Relay Layer shall send an RL-DATA.Confirm primitive to the Transport Layer. If the ACK_REQ field is set to '1' and the base station declares acknowledgment failure (see [9]), the Relay Layer shall send an RL-ERROR.Indication to the Transport Layer with error code set to the appropriate SMS_CauseCode value as defined in the SMS_CauseCode Table of [8].

If the RL-DATA.Request does not contain the confirmation request parameter, the base station may send the *Data Burst Message* either with or without Layer 2 acknowledgment. The Relay Layer should not return the RL-DATA.Confirm or the RL-ERROR.Indication for Layer 2 acknowledgment failure.

If the only connected service option is Service Option 6 or Service Option 14, the base station should release the traffic channel when no SMS messages have been received or sent during a period of time that is implementation dependent. After transmitting an SMS

1 message, the base station should delay the traffic channel release for a period of time
2 sufficient to allow the mobile station to return any requested acknowledgments.

3 2.4.2.2 Broadcast Procedures

4 This section defines the procedures for processing of mobile-terminated SMS messages that
5 are addressed to broadcast addresses. Broadcast SMS messages can be sent on the Paging
6 Channel, Forward Common Control Channel or the Broadcast Control Channel and these
7 messages can also be sent to individual mobile stations on the Forward Traffic Channel.

8 SMS messages addressed to broadcast addresses are received by the base station SMS
9 Relay Layer as RL-BCDATA.Request primitives from the Transport Layer.

10 When the base station Relay Layer receives an RL-BCDATA.Request primitive from the
11 Transport Layer, the Relay Layer should form a *Data Burst Message* (see 3.7.2.3.2.9 of [10]).
12 If a *Data Burst Message* is formed, the Relay Layer shall set BURST_TYPE to '000011' and
13 shall set the BC_ADDR field of the *Data Burst Message* to the value of the address
14 parameter of the RL-BCDATA.Request. The base station transmits the message on selected
15 Paging Channels or Broadcast Control Channel of selected CDMA channels in the selected
16 broadcast area. Procedures for selection of broadcast areas are outside the scope of this
17 standard. Procedures for selection of Paging Channels, Forward Common Control
18 Channels or Broadcast Control Channel and CDMA channels over which the *Data Burst*
19 *Message* is to be transmitted are outside the scope of this standard. The base station
20 should follow the procedures defined in [10] to deliver broadcast messages to mobile
21 stations operating in the slotted mode.

22 The base station shall set the MSG_NUMBER and NUM_MSGS fields to 1 and shall set the
23 NUM_FIELDS field to the number of octets in the SMS Transport Layer message. When
24 broadcast SMS messages are sent on a Paging Channel, Forward Common Control Channel
25 or Broadcast Control Channel, the base station shall set the ACK_REQ Layer 2 field to '0'.

26 When a broadcast SMS message is to be transmitted on the Paging Channel, the Forward
27 Common Control Channel or the Broadcast Control Channel, the base station shall
28 transmit the message following the procedures specified in 3.6.2 of [10]. The base station
29 shall not send any broadcast SMS message on a Paging Channel, which is not completely
30 contained, within three consecutive Paging Channel slots.

31 When the base station Relay Layer receives an RL-BCDATA.Request primitive from the
32 Transport Layer, the base station may also transmit the message to individual mobile
33 stations on the Forward Traffic Channel. When sending such messages on the Forward
34 Traffic Channel, the Relay Layer should form a *Data Burst Message* (see 3.7.2.3.2.9 of [10])
35 with BURST_TYPE set to '000011' and should send the *Data Burst Message* on the Forward
36 Traffic Channel using the procedures defined in 2.4.2.1.2.4, except that the base station
37 should set the ACK_REQ Layer 2 field to '0'. The base station should not page a mobile
38 station and assign it a Traffic Channel for the sole purpose of transmitting messages
39 contained in RL-BCDATA.Request primitives.

2.4.3 Base Station Procedures, N Interface

When an SMS message is received from the N Interface Link Layer, and the destination address is an individual mobile station, the Relay Layer shall pass the SMS message and the destination address to the Transport Layer using the RL-DATA.Indication primitive. The Relay Layer shall determine the parameters for the RL-DATA.Indication primitive as follows:

- The Relay Layer may include the confirmation request parameter in the RL-DATA.Indication primitive.
- If the N Interface is part of a network compliant with [8], the Relay Layer shall include the confirmation request parameter in the RL-DATA.Indication primitive.
- The Relay Layer shall include the destination address parameter in the RL-DATA.Indication primitive.
- If the N Interface is part of a network compliant with [8], the destination address, if present, shall be as indicated in the Original Destination Address information element; otherwise, the destination address shall be as indicated in the Destination Address information element.

When an SMS message is received from the N Interface Link Layer, and the destination address is a broadcast address, the Relay Layer shall pass the SMS message and the following parameters: Service Category, Priority Indicator, Zone Indicator, and Language Indicator to the Transport Layer using the RL-BCDATA.Indication primitive.

When an RL-DATA.Request is received from the Transport Layer, the Relay Layer shall use the message center destination address provided in the RL-DATA.Request to form a Link Layer message containing the SMS message and shall send the message to the message center via the Link Layer. The Relay Layer should return an RL-DATA.Confirm to the Transport Layer if the Link Layer transmission is successful and should send an RL-ERROR.Indication to the Transport Layer if the Link Layer transmission is unsuccessful. If the N Interface is part of a network compliant with [8], the Relay Layer shall place the address from the Destination Address parameter of the SMS message in the Original Destination Address information element and shall place the message center address in the Destination Address information element.

When an RL-DATA.Response is received from the Transport Layer, the Relay Layer should use the result parameter to send a positive or negative acknowledgment of message delivery on the N Interface Link Layer.

1 No text.

3 SMS TRANSPORT LAYER

3.1 Introduction

The SMS Transport Layer resides in SMS bearer service end points and relay points (see 1.5). In a bearer service end point, the SMS Transport Layer provides the means of access to the SMS system for Teleservices that generate or receive SMS messages. In a bearer service relay point, the Transport Layer provides an interface between Relay Layers.

3.2 Overview

3.2.1 Model of Operation

The SMS Transport Layers use Relay Layer services to originate, forward, and terminate SMS messages sent between mobile stations and message center(s). It is assumed that the Link Layers used by the Relay Layers support message addressing, so that certain address parameters can be inferred by the Relay Layer from Link Layer headers and are therefore not necessary in Transport Layer messages.

In particular, it is assumed that the *SMS Point-to-Point Message* does not require certain address parameters because the Link Layers will provide this address. On the Paging Channel or Forward Common Control Channel, for example, it can be assumed that the Relay Layer can extract the address from the ADDRESS field of the *Data Burst Message*. Requirements for the presence of address parameters are given with the message processing requirements in the following sections.

SMS Transport Layers have different functions in SMS bearer service end points and relay points, as discussed in 3.2.2.

3.2.2 Transport Layer Functions

3.2.2.1 Bearer Service End Points

In an SMS bearer service end point, the Transport Layer provides the following functions:

- Receiving message parameters from SMS Teleservices, formatting SMS Transport Layer messages, and passing the message to the Relay Layer using the appropriate Relay Layer service primitives.
- Informing the Relay Layer when all expected acknowledgments of submitted messages have been received.
- Informing the Teleservices when Relay Layer errors are reported.
- Receiving SMS messages from the Relay Layer and passing the messages to the SMS Teleservice.
- In mobile stations, performing authentication calculations as described in 3.3.3.1.

3.2.2.2 Bearer Service Relay Points

In an SMS bearer service relay point, the Transport Layer provides the following functions:

- 1 • Receiving SMS messages from a Relay Layer, reformatting the SMS Transport Layer
2 messages if necessary, and passing the message to another Relay Layer using the
3 appropriate Relay Layer service primitives.
- 4 • Passing confirmations or error reports between the Relay Layers if requested.
- 5 • Performing authentication calculations in base stations as described in 3.3.3.2 or
6 interfacing to the entities performing authentication calculations.

7 3.2.3 Service Description

8 3.2.3.1 Teleservice Interface

9 This standard does not formally define the interface between the Transport Layer and the SMS
10 Teleservice. This interface may be Teleservice-specific, and is implementation dependent.

11 3.2.3.2 Services Required from the Relay Layer

12 The Transport Layer requires the following services from the Relay Layer:

- 13 • Accepting Transport Layer messages and delivering them to the next indicated relay point
14 or end point.
- 15 • Returning confirmations or error reports for messages sent.
- 16 • Receiving messages and forwarding them to the Transport Layer with the appropriate
17 parameters.

18 3.3 Definition of Procedures

19 3.3.1 Relay Point Procedures, Base Station

20 In an SMS bearer service relay point, the Transport Layer serves as a connection between SMS
21 Relay Layers. The requirements of this section apply to the Transport Layer in the base station.

22 When the base station Transport Layer receives an RL-DATA.Indication from the U_m Interface
23 Relay Layer, and the message is an *SMS Point-to-Point Message*, it shall perform the following:

- 24 • If authentication is enabled in the serving system, the Transport Layer should perform
25 authentication procedures as described in 3.3.3.2.
- 26 • If the message does not include the Originating Address parameter, the Transport Layer
27 shall add the Originating Address parameter to the message. The contents of the
28 Originating Address parameter shall be determined from the address parameter of the
29 RL-DATA.Indication.
- 30 • If necessary, the Transport Layer shall reformat the message text for compatibility with
31 the corresponding N Interface protocols.
- 32 • The Transport Layer shall then send an RL-DATA.Request to the N Interface Relay Layer.
33 The address parameter of the RL-DATA.Request shall contain the address of the message
34 center that processes SMS messages for the mobile station.
- 35 • If the *SMS Point-to-Point Message* includes the Bearer Reply Option parameter, the base
36 station should form an *SMS Acknowledge Message*. If an error occurs, the base station

1 should include the Cause Codes parameter with the appropriate SMS_CauseCode value
2 as defined in the SMS_CauseCode Table of [8]. The base station should send the *SMS*
3 *Acknowledge Message* to the U_m Interface Relay Layer in an RL-DATA.Request within 18
4 seconds. The base station may wait for confirmation from the N Interface Relay Layer
5 before returning the *SMS Acknowledge Message*.

6 When the base station Transport Layer receives an RL-DATA.Indication from the U_m Interface
7 Relay Layer, and the message is an *SMS Acknowledge Message*, it shall perform the following:

- 8 • If authentication is enabled in the serving system, the Transport Layer should perform
9 authentication procedures as described in 3.3.3.2.
- 10 • The Transport Layer should then send an RL-DATA.Response to the N Interface Relay
11 Layer. The result parameter of the RL-DATA.Response shall contain the Cause Codes
12 value from the *SMS Acknowledge Message*. The base station should use the REPLY_SEQ
13 field of the Cause Codes parameter from the *SMS Acknowledge Message* to identify the
14 RL-DATA.Indication to which the RL-DATA.Response pertains.

15 When the base station Transport Layer receives an RL-DATA.Indication from the N Interface
16 Relay Layer, the Transport Layer shall perform the following:

- 17 • The Transport Layer shall form an *SMS Point-to-Point Message*. If necessary, the
18 Transport Layer shall reformat the message text for compatibility with this standard and
19 [10].
- 20 • The Transport Layer shall use the address parameter in the RL-DATA.Indication to
21 determine the destination mobile station.
- 22 • If the N Interface is part of a network compliant with [8], the Transport Layer shall
23 include the Originating Address parameter in the *SMS Point-to-Point Message*. The
24 Transport Layer shall set the Originating Address to the address contained in the Original
25 Originating Address information element, if present, otherwise to the address contained
26 in the Originating Address information element.
- 27 • If the RL-DATA.Indication from the N Interface contained the confirmation request
28 parameter, the Transport Layer shall include the Bearer Reply Option parameter in the
29 *SMS Point-to-Point Message*.
- 30 • The Transport Layer shall then send an RL-DATA.Request to the U_m Interface Relay
31 Layer. The RL-DATA.Request shall contain the processed message text from the
32 RL-DATA.Indication, and the address parameter of the RL-DATA.Request shall contain
33 the address of the destination mobile station. If the RL-DATA.Indication from the N
34 Interface contained the confirmation request parameter, the Transport Layer shall
35 include the confirmation request parameter in the RL-DATA.Request.
- 36 • If the Transport Layer receives an RL-ERROR.Indication from the U_m Interface Relay
37 Layer, it shall send an RL-DATA.Response to the N Interface Relay Layer with the result
38 parameter containing a cause code indicating the reason for failure.

39 When the base station Transport Layer receives an RL-BCDATA.Indication from the N Interface
40 Relay Layer, the Transport Layer shall perform the following:

- 1 • The Transport Layer shall form an *SMS Broadcast Message*. If necessary, the Transport
2 Layer shall reformat the message text for compatibility with this standard and [10].
- 3 • The Transport Layer shall include the Service Category parameter in the *SMS Broadcast*
4 *Message* and shall set the CATEGORY field to the value of the Service Category
5 parameter of the RL-BCDATA.Indication.
- 6 • The Transport Layer shall provide the address parameter in the RL-BCDATA.Request
7 sent to the U_m Relay Layer.

8 For the RL-BCDATA.Request the address parameter is 5 octets in length, and consists of the
9 following fields:

Field	Length (bits)
PRIORITY	2
MESSAGE_ID	6
ZONE_ID	8
SERVICE	16
LANGUAGE	8

11
12 The base station SMS Transport Layer sets the broadcast address fields for the message
13 according to the following rules:

- 14 • The base station shall set the PRIORITY field to the value of the Priority Indicator
15 parameter contained in the RL-BCDATA.Indication, if the Priority Indicator subparameter
16 is present.
- 17 • The base station shall use the MESSAGE_ID field to distinguish different messages from
18 the same broadcast service transmitted within the time period established for broadcast
19 duplicate detection in the mobile station (see [9]).
- 20 • The base station may set the ZONE_ID field to the value of the Zone Indicator parameter
21 contained in the RL-BCDATA.Indication. The base station may use the ZONE_ID field to
22 distinguish messages from the same broadcast service transmitted in different geographic
23 areas.
- 24 • The base station shall set the SERVICE field to the value of the Service Category
25 parameter contained in the RL-BCDATA.Indication.
- 26 • The base station shall set the LANGUAGE field to the value of the Language Indicator
27 parameter contained in the RL-BCDATA.Indication, if the Language Indicator
28 subparameter is present.

29 The Transport Layer shall then send the RL-BCDATA.Request to the U_m Interface Relay Layer.

3.3.2 End Point Procedures, Mobile Station

In an SMS bearer service end point, the Transport Layer serves as a connection between the SMS Teleservice and the Relay Layer. The requirements of this section apply to the Transport Layer in the mobile station.

When the mobile station Transport Layer receives an RL-DATA.Indication from the Relay Layer, and the message is not an *SMS Acknowledge Message*, the Transport Layer shall perform the following:

- The Transport Layer shall pass the SMS message to the appropriate Teleservice application. The Teleservice shall be determined from the Teleservice Identifier parameter in the message.
- If the SMS message includes the Bearer Reply Option Parameter, the Transport Layer shall form an *SMS Acknowledge Message*. If an error occurs, the Transport Layer should include the Cause Codes parameter with the appropriate SMS_CauseCode value as defined in the SMS_CauseCode Table of [8]. The Transport Layer shall set the Destination Address parameter to the value of the Originating Address parameter of the SMS message being acknowledged. The Transport Layer shall send the *SMS Acknowledge Message* to the Relay Layer in an RL-DATA.Request within 2 seconds. Provided that this timing requirement is met, the Transport Layer may wait for confirmation from the Teleservice before returning the *SMS Acknowledge Message*.

When the mobile station Transport Layer receives an RL-DATA.Indication from the Relay Layer, and the message is an *SMS Acknowledge Message*, the Transport Layer should inform the Teleservice. The mobile station should use REPLY_SEQ field of the Cause Codes parameter from the *SMS Acknowledge Message* to identify the RL-DATA.Request to which the *SMS Acknowledge Message* pertains.

When the mobile station SMS Transport Layer receives an RL-BCDATA.Indication from the Relay Layer, the Transport Layer shall pass the message to the broadcast message application.

When a mobile station Teleservice submits a message to an SMS service, it shall supply all message parameters to the Transport Layer. The Transport Layer shall perform the following:

- The Transport Layer shall form an *SMS Point-to-Point Message* containing the parameters supplied by the Teleservice.
- The Transport Layer shall then send an RL-DATA.Request to the Relay Layer, including the mobile station's address. The RL-DATA.Request may include the confirmation request parameter. If the Teleservice included the Bearer Reply Option with the parameters passed to the Transport Layer, the RL-DATA.Request should include the confirmation request parameter.
- If the RL-DATA.Request includes the confirmation request parameter, the Transport Layer should perform the following:
 - The Transport Layer may send multiple RL-DATA.Requests.
 - If the Transport Layer receives an RL-DATA.Confirm or an RL-ERROR.Indication from the Relay Layer, the Transport Layer should record the result.

- 1 - When a confirmation or error result has been received for all outstanding requests,
2 the Transport Layer should send an RL-CONTROL.Request to the Relay Layer.
- 3 • If the Transport Layer receives an RL-ERROR.Indication from the Relay Layer, the
4 Transport Layer should inform the Teleservice that the message submission was
5 unsuccessful.

6 3.3.3 Authentication Procedures

7 3.3.3.1 Mobile Station Procedures

8 If AUTH_s is equal to '1' in the mobile station, then the mobile station SMS Transport Layer shall
9 include the authentication parameter, as described below, in every RL-DATA.Request to the
10 Relay Layer.

11 The authentication parameter shall consist of zero to six 4-bit digits, encoded according to Table
12 2.7.1.3.2.4-4 in [10]. The digits shall be generated from the Destination Address as follows:

- 13 • If the CHAR_i fields (see 3.4.3.3) of the Destination Address represent 4-bit DTMF digits
14 (DIGIT_MODE='0'), then the Transport Layer shall include the least significant¹⁰ six digits of
15 the address in the authentication parameter.
- 16 • If the CHAR_i fields (see 3.4.3.3) of the Destination Address represent an 8-bit value
17 (DIGIT_MODE='1'), the Transport Layer shall perform the following:
- 18 - If a CHAR_i field represents one of the digits 0-9, *, or #, the digit shall be encoded
19 according to Table 2.7.1.3.2.4-4 in [10].
- 20 - If the CHAR_i field represents any other character, the Transport Layer shall convert
21 each CHAR_i field to its decimal equivalent (treated as an unsigned binary number)
22 and select the least significant digit of the decimal equivalent of each CHAR_i field.
23 Then the Transport Layer shall include the least significant six decimal digits from
24 this set.
- 25 • If there are fewer than six digits, then the Transport Layer shall include all of the digits in the
26 authentication parameter with an indication of how many digits have been included. The
27 sequence of digits in the authentication parameter shall be used to compute the
28 authentication fields of the *Data Burst Message* in accordance with [9].

29 3.3.3.2 Base Station Procedures

30 If authentication is enabled in the serving system, the base station SMS Transport Layer should
31 form the authentication digits, as described in 3.3.3.1, from the message contents in each
32 RL-DATA.Indication received from the U_m Interface Relay Layer. The base station should use
33 the sequence of digits to compute the authentication signature in accordance with [9] and
34 should compare the computed signature with the authentication parameter of the
35 RL-DATA.Indication, as discussed in [9].
36

¹⁰For addresses consisting of a sequence of digits, the last digits in the sequence are considered least significant.

3.4 Transport Layer Messages

The SMS Transport Layer messages are summarized in Table 3.4-1.

Table 3.4-1. SMS Transport Layer Messages

Message Type	base station -> mobile station	mobile station -> base station	SMS_MSG_TYPE
SMS Point-to-Point	X	X	'00000000'
SMS Broadcast	X		'00000001'
SMS Acknowledge	X	X	'00000010'
All other values are reserved.			

3.4.1 Message Format

All SMS Transport Layer messages shall use the following variable-length format:

Field	Length (bits)
SMS_MSG_TYPE	8

One or more occurrences of the following parameter record:

PARAMETER_ID	8
PARAMETER_LEN	8
Parameter Data	8×PARAMETER_LEN

SMS_MSG_TYPE - SMS message type.

See Table 3.4-1.

PARAMETER_ID - SMS message parameter identifier.

See Table 3.4.3-1.

PARAMETER_LEN - SMS message parameter length.

This field shall be set to the number of octets in the SMS message parameter, not including the PARAMETER_ID and PARAMETER_LEN fields.

Parameter Data - Parameter data fields.

See 3.4.3.

3.4.2 Message Definitions

The following sections define the contents of the SMS Transport Layer Messages. Message parameters can be in any order within a message.

3.4.2.1 SMS Point-to-Point Message

The *SMS Point-to-Point Message* includes the following parameters:

Table 3.4.2.1-1. SMS Point-to-Point Message Parameters

Parameter	Reference	Type
Teleservice Identifier	3.4.3.1	Mandatory
Service Category	3.4.3.2	Optional
Originating Address	3.4.3.3	Mandatory (1)
Originating Subaddress	3.4.3.4	Optional (1)
Destination Address	3.4.3.3	Mandatory (2)
Destination Subaddress	3.4.3.4	Optional (2)
Bearer Reply Option	3.4.3.5	Optional
Bearer Data	3.4.3.7	Optional
(1) For mobile-terminated messages (not present in mobile-originated messages)		
(2) For mobile-originated messages (not present in mobile-terminated messages)		

3.4.2.2 SMS Broadcast Message

The *SMS Broadcast Message* includes the following parameters:

Table 3.4.2.2-1. SMS Broadcast Message Parameters

Parameter	Reference	Type
Service Category	3.4.3.2	Mandatory
Bearer Data	3.4.3.7	Optional

3.4.2.3 SMS Acknowledge Message

The *SMS Acknowledge Message* includes the following parameters:

Table 3.4.2.3-1. SMS Acknowledge Message Parameters

Parameter	Reference	Type
Destination Address	3.4.3.3	Mandatory (1)
Destination Subaddress	3.4.3.4	Optional
Cause Codes	3.4.3.6	Mandatory
(1) For mobile-originated messages (not present in mobile-terminated messages)		

3.4.3 Parameter Definitions

Table 3.4.3-1 lists the parameters used in Transport Layer messages.

Table 3.4.3-1. Parameter Identifiers

Parameter	PARAMETER_ID Value
Teleservice Identifier	'00000000'
Service Category	'00000001'
Originating Address	'00000010'
Originating Subaddress	'00000011'
Destination Address	'00000100'
Destination Subaddress	'00000101'
Bearer Reply Option	'00000110'
Cause Codes	'00000111'
Bearer Data	'00001000'
All other values are reserved.	

10

11

3.4.3.1 Teleservice Identifier

The Teleservice Identifier parameter identifies which upper layer service access point is sending or should receive this message.

The Teleservice Identifier parameter has the following fixed-length format:

Field	Length (bits)
PARAMETER_ID	8
PARAMETER_LEN	8
IDENTIFIER	16

PARAMETER_ID - SMS parameter identifier.

This field shall be set to '00000000'.

PARAMETER_LEN - SMS message parameter length.

This field shall be set to '00000010'.

IDENTIFIER - Teleservice identifier.

This field shall be set to the value corresponding to the Teleservice, as defined in the SMS_TELESERVICE Identifier Values Table in [8] (See Table 175 in Section 6.5.2). The Teleservices supported in this standard are listed in Table 3.4.3.1-1.

Table 3.4.3.1-1. Supported Teleservices

CDMA Teleservice	Network Teleservice
IS-91 Extended Protocol Enhanced Services	CMT-91
Wireless Paging Teleservice	CPT-95
Wireless Messaging Teleservice	CMT-95
Voice Mail Notification	VMN-95
Wireless Application Protocol	WAP
Wireless Enhanced Messaging Teleservice	WEMT
Service Category Programming Teleservice	SCPT
Card Application Toolkit Protocol Teleservice	CATPT

1 3.4.3.2 Service Category

2 The Service Category parameter identifies the type of service supported by the SMS message.

3 The Service Category parameter has the following fixed-length format:

4

Field	Length (bits)
PARAMETER_ID	8
PARAMETER_LEN	8
CATEGORY	16

5

6 PARAMETER_ID - SMS parameter identifier.

7 This field shall be set to '00000001'.

8 PARAMETER_LEN - SMS message parameter length.

9 This field shall be set to '00000010'.

10 CATEGORY - Service Category.

11 This field shall be set according to Table 9.3.1-1 as defined
12 in Section 9.3 of [15].

13

14

3.4.3.3 Address Parameters

The address parameters have the following variable-length format:

Field	Length (bits)
PARAMETER_ID	8
PARAMETER_LEN	8
DIGIT_MODE	1
NUMBER_MODE	1
NUMBER_TYPE	0 or 3
NUMBER_PLAN	0 or 4
NUM_FIELDS	8

NUM_FIELDS occurrences of the following field:

CHAR _i	4 or 8
-------------------	--------

The parameter ends with the following field:

RESERVED	0-7
----------	-----

- PARAMETER_ID - SMS parameter identifier.
- For the Originating Address parameter, this field shall be set to '00000010'.
- For the Destination Address parameter, this field shall be set to '00000100'.
- PARAMETER_LEN - SMS message parameter length.
- This field shall be set to the number of octets in the parameter, not including the PARAMETER_ID and PARAMETER_LEN fields.
- DIGIT_MODE - Digit mode indicator.
- This field indicates whether the address digits are 4-bit DTMF codes or 8-bit codes.
- To specify an address using the binary representation of DTMF digits, this field shall be set to '0'. To specify an address using 8-bit characters, this field shall be set to '1'.
- NUMBER_MODE - Number mode indicator.
- This field indicates whether the address type is as defined in [6] or is a data network address.

To specify an address using the definitions in [6], this field shall be set to '0'. To specify an address using data network address formats, this field shall be set to '1'. With the exception of email addresses, data network addresses shall be encoded as binary numbers with the most significant octet of the address first. E-mail addresses shall be encoded as 8-bit ASCII characters.

NUMBER_TYPE

- Type of number.

If the DIGIT_MODE field is set to '1' and the NUMBER_MODE field is set to '0', this field shall be set to the NUMBER_TYPE value shown in Table 2.7.1.3.2.4-2 of [10] corresponding to the type of the number as defined in 4.5.9 of [6].

If the DIGIT_MODE field is set to '1' and the NUMBER_MODE field is set to '1', this field shall be set to the NUMBER_TYPE value shown in Table 3.4.3.3-1.

If the DIGIT_MODE field is set to '0', this field shall be omitted.

Table 3.4.3.3-1. Data Network Address Number Types

Number Type	NUMBER_TYPE value
Unknown	'000'
Internet Protocol [16]	'001'
Internet Email Address [17]	'010'
All other values are reserved.	

NUMBER_PLAN

- Numbering plan.

If the DIGIT_MODE field is set to '1' and the NUMBER_MODE field is set to '0', this field shall be set to the NUMBER_PLAN value shown in Table 2.7.1.3.2.4-3 of [10] corresponding to the requested numbering plan. If the DIGIT_MODE field is set to '0', or if the NUMBER_MODE field is set to '1' this field shall be omitted.

NUM_FIELDS

- Number of digits in this parameter.

This field shall be set to the number of address digits or characters included in this parameter.

When the address indicates the home Message Center for a mobile station, the Message Center address digits may be

1 omitted, in which case NUM_FIELDS shall be set to
2 '00000000'.
3 CHARi - An address digit or character.
4 This parameter shall include NUM_FIELDS occurrences of
5 this field.
6 If the DIGIT_MODE field is set to '0', each occurrence of this
7 field shall be set to the code value shown in Table
8 2.7.1.3.2.4-4 of [10] corresponding to the address digit.
9 If the DIGIT_MODE field is set to '1' and the
10 NUMBER_MODE field is set to '0', each occurrence of this
11 field shall be set to the ASCII representation corresponding
12 to the address digit or character, as specified in [7], with the
13 most significant bit set to '0'.
14 If the DIGIT_MODE field is set to '1', the NUMBER_MODE
15 field is set to '1', and the NUMBER_TYPE field is set to '010',
16 each occurrence of this field shall be set to an 8-bit ASCII
17 character of the Internet e-mail address. The CHARi fields
18 may include more than one e-mail address, with a comma
19 separating each address. For example, the CHARi fields
20 can be set to "x@y.com,a@b.com".
21 If the DIGIT_MODE field is set to '1', the NUMBER_MODE
22 field is set to '1', and the NUMBER_TYPE field is set to '001',
23 each occurrence of this field shall be set to the binary value
24 of an octet of the data network address, with the most
25 significant octet first.
26 RESERVED - Reserved bits.
27 This field shall contain the number of bits required to make
28 the entire parameter an integer number of octets in length.
29 This field shall be set to all zeros.
30

3.4.3.4 Subaddress

The Originating Subaddress identifies the subaddress of the originator of the SMS message. The Destination Subaddress identifies the subaddress of the destination of the SMS message.

The Originating Subaddress and Destination Subaddress parameters have the following variable-length format:

Field	Length (bits)
PARAMETER_ID	8
PARAMETER_LEN	8
TYPE	3
ODD	1
NUM_FIELDS	8

NUM_FIELDS instances of the following field:

CHARi	8
-------	---

The parameter ends with the following field:

RESERVED	4
----------	---

- 7
- 8 PARAMETER_ID - SMS parameter identifier.
- 9 For Originating Subaddress, this field shall be set to
- 10 '00000011'.
- 11 For Destination Subaddress, this field shall be set to
- 12 '00000101'.
- 13 PARAMETER_LEN - SMS message parameter length.
- 14 This field shall be set to the number of octets in the
- 15 parameter, not including the PARAMETER_ID and
- 16 PARAMETER_LEN fields.
- 17 TYPE - Subaddress type.
- 18 This field shall be set to the subaddress coding type, as
- 19 given in Table 3.4.3.4-1.
- 20

Table 3.4.3.4-1. Subaddress Type Values

TYPE	Subaddress type
'000'	NSAP ([4] or [2])
'001'	User-specified
All other values are reserved.	

1
2
3
4
5
6
7
8
9
10
11
12
13
14
15
16
17
18
19
20
21
22
23
24
25
26
27
28

- ODD - Odd/even indicator.
- If the last CHAR_i field contains information only in the 4 most significant bits, the ODD field shall be set to '1'. Otherwise, the ODD field shall be set to '0'.
- NUM_FIELDS - Number of CHAR_i fields in this parameter.
- This field shall be set to the number of CHAR_i fields included in this parameter.
- CHAR_i - A subaddress octet.
- The mobile station shall include NUM_FIELDS occurrences of this field.
- When the TYPE field is set to '000', the NSAP shall be encoded in the CHAR_i fields using the preferred binary encoding specified in [4] or [2]. When the AFI is equal to 50 (encoded in BCD as 0101 0000), IA5 characters are encoded as specified in Table 11 of [3] or [1], with the most significant bit set to '0'. When the AFI is equal to 51 (encoded in BCD as 0101 0001), ASCII characters are encoded as specified in [7], with the most significant bit set to '0'.
- When the TYPE field is set to '001', the subaddress encoding is according to user specifications. When interworking with a network compliant with [5], BCD coding should be used.
- RESERVED - Reserved bits.
- All bits of this field shall be set to zeros.

3.4.3.5 Bearer Reply Option

The Bearer Reply Option parameter is used to request return of an *SMS Acknowledge Message*.

The Bearer Reply Option parameter has the following fixed-length format:

Field	Length (bits)
PARAMETER_ID	8
PARAMETER_LEN	8
REPLY_SEQ	6
RESERVED	2

- PARAMETER_ID - SMS parameter identifier.
This field shall be set to '00000110'.
- PARAMETER_LEN - SMS message parameter length.
This field shall be set to '00000001'.
- REPLY_SEQ - Reply sequence number.
This field shall be set to a value identifying the SMS message for which acknowledgment is requested.
- RESERVED - Reserved bits.
All bits of this field shall be set to zeros.

3.4.3.6 Cause Codes

The Cause Codes parameter is an indication whether an SMS error has occurred and if so, whether the condition is considered temporary or permanent.

The Cause Codes parameter has the following variable-length format:

Field	Length (bits)
PARAMETER_ID	8
PARAMETER_LEN	8
REPLY_SEQ	6
ERROR_CLASS	2
CAUSE_CODE	0 or 8

- PARAMETER_ID - SMS parameter identifier.
This field shall be set to '00000111'.
- PARAMETER_LEN - SMS message parameter length.
This field shall be set to the number of octets in the parameter, not including the PARAMETER_ID and PARAMETER_LEN fields.
- REPLY_SEQ - Reply sequence number.
This field shall be set to the reply sequence number in the Bearer Reply Option parameter of the message being acknowledged.
- ERROR_CLASS - Error report class.
If there is no error, this field shall be set to '00'.
If the error is caused by a temporary condition, this field shall be set to '10'. If the error is caused by a permanent condition, this field shall be set to '11'.
The value '01' is reserved.
- CAUSE_CODE - Error cause identifier.
If the ERROR_CLASS field is set to '00', this field shall be omitted. Otherwise, this field shall be set to the appropriate SMS_CauseCode, as defined in the SMS_CauseCode Table of [8].

3.4.3.7 Bearer Data

The Bearer Data parameter has the following variable-length format:

Field	Length (bits)
PARAMETER_ID	8
PARAMETER_LEN	8

One or more occurrences of the following subparameter record:

SUBPARAMETER_ID	8
SUBPARAM_LEN	8
Subparameter Data	8×SUBPARAM_LEN

- PARAMETER_ID - SMS parameter identifier.
This field shall be set to '00001000'.
- PARAMETER_LEN - SMS message parameter length.
This field shall be set to the number of octets in the parameter, not including the PARAMETER_ID and PARAMETER_LEN fields.
- SUBPARAMETER_ID - Subparameter identifier.
See Table 4.5-1.
- SUBPARAM_LEN - Subparameter length.
This field shall be set to the number of octets in the subparameter, not including the SUBPARAMETER_ID and SUBPARAM_LEN fields.
- Subparameter Data - Subparameter data fields.
See 4.5.

1

2 No text.

3

4 SMS TELESERVICE LAYER

4.1 Introduction

The SMS Teleservice Layer resides in a Bearer Service end point (see 1.5). The Teleservice Layer supports basic SMS functions through a standard set of subparameters of the Transport Layer's Bearer Data parameter.

4.2 Overview

The Teleservice support defined in this standard is restricted to definition of the Teleservice messages and their contents, and definition of the minimum set of procedural requirements necessary to ensure compatibility.

The message type is indicated in the Message Identifier subparameter. Teleservice message types are summarized in Table 4.5.1-1.

4.3 Teleservice Procedures

4.3.1 General

4.3.1.1 Mobile Station Message Termination

When a mobile station receives an *SMS Deliver Message* it shall perform the following:

- If the mobile station and the teleservice support unique message identification, then the mobile station shall perform the related procedures (see 4.3.1.6).
- If the mobile station supports the Validity Period subparameters, then the mobile station shall consider the received SMS Deliver as valid according to the Validity Period - Absolute or Validity Period - Relative subparameter.
- If an Alert on Message Delivery subparameter is included in the *SMS Deliver Message*, and the mobile station is configured to alert upon message delivery, the mobile station shall alert the user.
- If a Reply Option subparameter received in an *SMS Deliver Message* indicates that User Acknowledgment is requested, the mobile station should indicate the request to the user. When the user acknowledges the message, the mobile station should send an *SMS User Acknowledgment Message* in response to the *SMS Deliver Message*.
- If a Reply Option subparameter received in an *SMS Deliver Message* indicates that Read Acknowledgment is requested and if the Read Acknowledgment feature is enabled on the mobile, the mobile station should, when the user opens the message, send an *SMS Read Acknowledgment Message* in response to the *SMS Deliver Message*.

When a mobile station sends an *SMS User Acknowledgment Message* or an *SMS Read Acknowledgment Message*, the Teleservice Layer shall perform the following:

- The Teleservice Layer shall supply the Destination Address parameter to the Transport Layer, and shall set the Destination Address parameter equal to the address contained in the Originating Address field of the SMS message being acknowledged.

- The MESSAGE_ID field of the Message Identifier subparameter shall be set to the value of the MESSAGE_ID field in the SMS message being acknowledged.

When a mobile station receives an *SMS User Acknowledgment Message*, an *SMS Read Acknowledgment Message*, or an *SMS Delivery Acknowledgment Message*, the actions to be taken are implementation dependent.

4.3.1.2 Mobile Station Message Origination

The mobile station shall send the *SMS Submit Message* when originating a new SMS message. The mobile station shall set the MESSAGE_ID field of the Message Identifier subparameter as described in Section 4.3.1.5.

4.3.1.3 Broadcast Messaging Service

Broadcast Messaging Service Teleservice messages are sent using the *SMS Deliver Message*. Table 4.3.1.3-1 lists the subparameters used by the Broadcast Messaging Service in the *SMS Deliver Message*. The mobile station may ignore subparameters not listed in Table 4.3.1.3-1. If the Language Indicator Subparameter is not included in the received Bearer Data subparameters, the mobile station should use the default language set in the mobile station. If Priority Indicator is not included in the received Bearer Data subparameters, the mobile station should use '00' (normal) as the default value for Priority Indicator.

Table 4.3.1.3-1. SMS Deliver Message Subparameters, Broadcast Messaging Service

Subparameter	Reference	Type
Message Identifier	4.5.1	Mandatory
User Data	4.5.2	Optional
Message Center Time Stamp	4.5.4	Optional
Validity Period - Absolute	4.5.5	Optional
Validity Period - Relative	4.5.6	Optional
Priority Indicator	4.5.9	Optional
Alert on Message Delivery	4.5.13	Optional
Language Indicator	4.5.14	Optional
Call-Back Number	4.5.15	Optional
Message Display Mode	4.5.16	Optional
Multiple Encoding User Data	4.5.17	Optional

4.3.1.4 Analog Mode SMS Services

Dual-mode mobile stations support limited short message delivery while operating in the analog mode. In the analog mode, mobile stations support message termination only. The

1 Teleservices defined in this standard are supported by mobile stations in the analog mode,
2 with the following restrictions and modifications.

3 4.3.1.4.1 Extended Protocol SMS Services

4 Extended Protocol Enhanced Services of [14] deliver mobile-terminated messages with the
5 message type (MST) field set appropriately for each application. The mobile station shall
6 process the contents of such extended protocol messages as Bearer Data subparameters
7 (see 4.5), using the mapping shown in Table 4.3.1.4.1-1 between MST values and the
8 Bearer Data subparameters. Refer to 3.7.1.1 of [14] for definitions of fields of the extended
9 protocol messages.

10
11 **Table 4.3.1.4.1-1. Bearer Data Subparameters for Extended Protocol Messages**

MST	Subparameters	Message Fields
CLI Order	Call-Back Number (1) Alert on Message Delivery (2)	DIGIT1 – DIGIT32 (Implicit)
Voice Mail	Number of Messages (3) Priority Indicator (5) User Data (4) Alert on Message Delivery (2)	CHAR1 – CHAR2 CHAR3 CHAR4 - CHAR14 (Implicit)
Short Message	User Data (4) Alert on Message Delivery (2)	CHAR1 – CHAR14 (Implicit)

(1) CHARi fields of the Call-Back Number subparameter (see 4.5.15). DIGIT_MODE is assumed equal to '0'.

(2) If the mobile station is configured to alert upon message delivery, the mobile station shall alert the user.

(3) MESSAGE_CT field of the Number of Messages subparameter (see 4.5.12), but with CHAR1 and CHAR2 each containing a digit 0-9 formatted according to Appendix B of [14].

(4) The indicated CHARn fields of the extended protocol message are the CHARi fields of the User Data subparameter (see 4.5.2), with each character formatted according to Appendix B of [14]. Characters are text information only.

(5) If the Priority Indicator subparameter (see 4.5.9) is not included or if the PRIORITY field in the Priority Indicator subparameter is set to '00' (Normal) or '01' (Interactive), CHAR3 should be set to a space ('000000') which identifies the message as normal. If the PRIORITY field in the Priority Indicator subparameter is set to '10' (Urgent) or '11' (Emergency), CHAR3 should be set to an exclamation mark '?' ('000001') which identifies the message as urgent.

12

13

4.3.1.4.2 Alert With Info SMS Services

The *Alert With Info SMS Message* and the corresponding *Order Confirmation Message* on the analog channels replace the Transport Layer and Relay Layer services defined in this standard. The *Alert With Info SMS Message* carries a Teleservice message functionally equivalent to the *SMS Deliver Message*. All Teleservices defined in this standard may be supported by analog *Alert With Info SMS Messages*. The INFO_DATA fields of the *Alert With Info SMS Message* shall contain the SMS Teleservice message. The first 16 bits of the *SMS Teleservice Message* shall contain the Teleservice Identifier as specified in Table 3.4.3.1-1 in the following format:

Field	Length (bits)
IDENTIFIER	16

IDENTIFIER - Teleservice identifier.

This field shall be set to the value corresponding to the Teleservice, as defined in the SMS_TELESERVICE Identifier Values Table in [8]. The Teleservices supported in this standard are listed in Table 3.4.3.1-1.

The remaining bits of the *SMS Teleservice Message* shall contain one or more subparameters in the following format:

Field	Length (bits)
SUBPARAMETER_ID	8
SUBPARAM_LEN	8
Subparameter Data	8×SUBPARAM_LEN

SUBPARAMETER_ID - Subparameter identifier.

See Table 4.5-1.

SUBPARAM_LEN - Subparameter length.

This field shall be set to the number of octets in the subparameter, not including the SUBPARAMETER_ID and SUBPARAM_LEN fields.

Subparameter Data - Subparameter data fields.

See 4.5.

The Message Identifier subparameter is optional in analog *Alert With Info SMS Messages*. SMS messages carried as *Alert With Info SMS Messages* are, by default, *SMS Deliver*

1 *Messages*. Other message types may be used in future implementations. If the Message
2 Identifier subparameter is present in an analog *Alert With Info SMS Message* and the
3 MESSAGE_TYPE field is not equal to '0001' (*SMS Deliver Message*), the mobile station may
4 ignore the message. If the Message Identifier subparameter is present in an analog *Alert*
5 *With Info SMS Message*, the mobile station should use the MESSAGE_ID field to detect
6 duplicate *SMS Teleservice Messages*.

7 The Reply Option subparameter should not be included in analog *Alert With Info SMS*
8 *Messages*. If this subparameter is received by a mobile station while in analog mode, the
9 mobile station shall ignore the subparameter.

10 4.3.1.5 Setting of Message Identifier Field

11 The MESSAGE_ID field of the Message Identifier Subparameter is a value used to identify
12 sent SMS messages.

13 If the message is a WAP Teleservice message, the mobile station shall set the MESSAGE_ID
14 field as specified Section 6.5.3 of [~~1824~~].

15 Otherwise, the mobile station shall increment the MESSAGE_ID field, modulo 65536, for
16 each new message sent. Upon power-up, the mobile station should select a MESSAGE_ID
17 field value for the first such message sent using a procedure that minimizes the likelihood
18 of reusing the same MESSAGE_ID field value in consecutive *SMS Submit Messages*.¹¹

19 4.3.1.6 Unique Message Identification

20 Unique message identification enables mobile stations to identify repeated messages and to
21 process them accordingly. Fields from the SMS message are used by the Teleservice Layer
22 to uniquely identify a message.

23 Not all Teleservices support unique message identification. The WAP Teleservice does not
24 support unique message identification.

25 The fields used to identify a message are:

- 26 • Message Identifier,
- 27 • Originating Address,
- 28 • Originating Subaddress, and
- 29 • Message Center Time Stamp.

30
31 Since some of the fields are optional, the Teleservice Layer shall use as many of the fields
32 as are present in the SMS message to determine message uniqueness. Mobile stations
33 should discard repeated messages.

¹¹ An acceptable method is to select a random value in the range from 0 to 65535 for the MESSAGE_ID field of the first SMS message submitted.

4.3.2 IS-91 Extended Protocol Enhanced Services

This Teleservice provides a means of delivering messages equivalent to those used in the Extended Protocol Enhanced Services defined in [14]. This Teleservice is a point-to-point service only, supporting only mobile-terminated messages.

For this Teleservice, SMS messages shall contain only the User Data subparameter. The MSG_ENCODING field of the User Data subparameter shall be set to '00001'. The CHARi fields of the User Data subparameter shall contain the CHARn or DIGITn fields of the equivalent extended protocol message (see 3.7.1.1 of [14]), as determined by the value of the MST field of the User Data subparameter. The CHARi fields of the User Data subparameter shall be processed in the same manner as the corresponding Teleservice subparameters according to the mapping shown in Table 4.3.1.4.1-1 for the value of the MST field in the User Data subparameter.

Short messages compliant with [14] should not be segmented when carried by this Teleservice. Mobile stations supporting this Teleservice are not required to concatenate messages containing STX characters.

Table 4.3.2-1 lists the subparameters used by this Teleservice in the *SMS Deliver Message*. The mobile station may ignore subparameters not listed in Table 4.3.2-1.

Table 4.3.2-1. SMS Deliver Message Subparameters, CMT-91

Subparameter	Reference	Type
Message Identifier	4.5.1	Mandatory
User Data	4.5.2	Mandatory

4.3.3 Wireless Paging Teleservice (WPT)

The Wireless Paging Teleservice (WPT) is described in 6.2 of [11]. This Teleservice uses the *SMS Deliver Message*, and optionally the *SMS Submit Message*, the *User Acknowledgment Message* and the *SMS Delivery Acknowledgment Message*. WPT does not support message cancellation. WPT is a point-to-point service only.

Table 4.3.3-1 lists the subparameters used by WPT in the *SMS Deliver Message*. The mobile station may ignore subparameters not listed in Table 4.3.3-1.

Table 4.3.3-1. SMS Deliver Message Subparameters, WPT

Subparameter	Reference	Type
Message Identifier	4.5.1	Mandatory
User Data	4.5.2	Optional
Message Center Time Stamp	4.5.4	Optional
Priority Indicator	4.5.9	Optional
Privacy Indicator	4.5.10	Optional
Reply Option	4.5.11	Optional
Number of Messages	4.5.12	Optional
Call-Back Number	4.5.15	Optional
Message Display Mode	4.5.16	Optional
Multiple Encoding User Data	4.5.17	Optional
Message Deposit Index	4.5.18	Optional

When the mobile station receives a WPT *SMS Deliver Message* it shall perform alerting as configured by the mobile station user.

Table 4.3.3-2 lists the subparameters used by WPT in the *SMS Submit Message*. The message center may ignore subparameters not listed in Table 4.3.3-2.

Table 4.3.3-2. SMS Submit Message Subparameters, WPT

Subparameter	Reference	Type
Message Identifier	4.5.1	Mandatory
User Data	4.5.2	Optional
Priority Indicator	4.5.9	Optional
Privacy Indicator	4.5.10	Optional
Reply Option	4.5.11	Optional
Call-Back Number	4.5.15	Optional
Multiple Encoding User Data	4.5.17	Optional
Message Deposit Index	4.5.18	Optional

When the message center receives a WPT *SMS Submit Message* whose destination is a mobile station, the message center should use the contents of the *SMS Submit Message* to form a WPT *SMS Deliver Message* and send it to the destination mobile station.

1 All subparameters of the *SMS User Acknowledgment Message*, listed in Table 4.4.4-1, may
2 be used by WPT.

3 All subparameters of the *SMS Delivery Acknowledgment Message*, listed in Table 4.4.5-1,
4 may be used by WPT. This message is originated by the message center in response to an
5 *SMS Submit Message* with the DAK_REQ field set to '1'. The message center shall send this
6 message to the originating mobile station when the final destination confirms receipt of the
7 submitted message. If the final destination is a mobile station, the message center should
8 send the *SMS Delivery Acknowledgment Message* when informed that the destination
9 mobile station has returned a Transport Layer *SMS Acknowledgment Message*. The
10 message center may send the *SMS Delivery Acknowledgment Message* to indicate the status
11 of a message. The message center may include the User Data subparameter containing a
12 status message, the Message Status Subparameter, or both. If both the User Data
13 subparameter and the Message Status Subparameter are included in the message, and the
14 mobile station supports the Message Status Subparameter, the User Data Subparameter
15 may be ignored. The Message Center Time Stamp subparameter should contain the time at
16 which the *SMS Delivery Acknowledgment Message* was sent.

17 4.3.4 Wireless Messaging Teleservice (WMT)

18 The Wireless Messaging Teleservice (WMT) is described in 6.3 of [11]. This Teleservice uses
19 the *SMS Deliver Message*, and optionally the *SMS Submit Message*, the *SMS Cancellation*
20 *Message*, the *SMS User Acknowledgment Message*, the *SMS Read Acknowledgment Message*
21 and the *SMS Delivery Acknowledgment Message*. WMT is a point-to-point service only.

22 Table 4.3.4-1 lists the subparameters used by WMT in the *SMS Deliver Message*. The
23 mobile station may ignore subparameters not listed in Table 4.3.4-1.

24

1

Table 4.3.4-1. SMS Deliver Message Subparameters, WMT

Subparameter	Reference	Type
Message Identifier	4.5.1	Mandatory
User Data	4.5.2	Optional
Message Center Time Stamp	4.5.4	Optional
Validity Period – Absolute	4.5.5	Optional
Validity Period – Relative	4.5.6	Optional
Priority Indicator	4.5.9	Optional
Privacy Indicator	4.5.10	Optional
Reply Option	4.5.11	Optional
Number of Messages	4.5.12	Optional
Alert on Message Delivery	4.5.13	Optional
Language Indicator	4.5.14	Optional
Call-Back Number	4.5.15	Optional
Message Display Mode	4.5.16	Optional
Multiple Encoding User Data	4.5.17	Optional
Message Deposit Index	4.5.18	Optional

2

3 Table 4.3.4-2 lists the subparameters used by WMT in the *SMS Submit Message*. The
4 mobile station may ignore subparameters not listed in Table 4.3.4-2. When the message
5 center receives a WMT *SMS Submit Message* whose destination is a mobile station, the
6 message center should use the contents of the *SMS Submit Message* to form a WMT *SMS*
7 *Deliver Message* and send it to the destination mobile station.

Table 4.3.4-2. SMS Submit Message Subparameters, WMT

Subparameter	Reference	Type
Message Identifier	4.5.1	Mandatory
User Data	4.5.2	Optional
Validity Period – Absolute	4.5.5	Optional
Validity Period – Relative	4.5.6	Optional
Deferred Delivery Time - Absolute	4.5.7	Optional
Deferred Delivery Time - Relative	4.5.8	Optional
Priority Indicator	4.5.9	Optional
Privacy Indicator	4.5.10	Optional
Reply Option	4.5.11	Optional
Alert on Message Delivery	4.5.13	Optional
Language Indicator	4.5.14	Optional
Call-Back Number	4.5.15	Optional
Multiple Encoding User Data	4.5.17	Optional
Message Deposit Index	4.5.18	Optional

When the message center receives an *SMS Cancellation Message* it should return an *SMS Delivery Acknowledgment Message* with the User Data subparameter containing a message indicating either cancellation of the submitted message or that the message has already been delivered.

All subparameters of the *SMS User Acknowledgment Message*, listed in Table 4.4.4-1, may be used by WMT.

All subparameters of the *SMS Read Acknowledgment Message*, listed in Table 4.4.6-1, may be used by WMT.

All subparameters of the *SMS Delivery Acknowledgment Message*, listed in Table 4.4.5-1, may be used by WMT. This message is originated by the message center in response to an *SMS Submit Message* with the DAK_REQ field set to '1'. The message center shall send this message to the originating mobile station when the final destination confirms receipt of the submitted message. If the final destination is a mobile station, the message center should send the *SMS Delivery Acknowledgment Message* when informed that the destination mobile station has returned a *Transport Layer SMS Acknowledgment Message*. The message center may send the *SMS Delivery Acknowledgment Message* to indicate the status of a message. The message center may include the User Data subparameter containing a status message, the Message Status Subparameter, or both. If both the User Data Subparameter and the Message Status Subparameter are included in the message, and the mobile station supports the Message Status Subparameter, the User Data Subparameter

1 may be ignored. The Message Center Time Stamp subparameter should contain the time at
2 which the *SMS Delivery Acknowledgment Message* was sent.

3 4.3.5 Voice Mail Notification (VMN)

4 The Voice Mail Notification (VMN) Teleservice is an extension of the capability provided by
5 the Voice Mail Status extended protocol enhanced feature defined in [14]. This Teleservice
6 uses the *SMS Deliver Message*. VMN is a point-to-point service only.

7 Table 4.3.5-1 lists the subparameters used by VMN in the *SMS Deliver Message*. The
8 mobile station may ignore subparameters not listed in Table 4.3.5-1.

9
10 **Table 4.3.5-1. SMS Deliver Message Subparameters, VMN**

Subparameter	Reference	Type
Message Identifier	4.5.1	Mandatory
User Data	4.5.2	Optional
Message Center Time Stamp	4.5.4	Optional
Priority Indicator	4.5.9	Optional
Privacy Indicator	4.5.10	Optional
Number of Messages	4.5.12	Mandatory
Alert on Message Delivery	4.5.13	Optional
Call-Back Number	4.5.15	Optional
Multiple Encoding User Data	4.5.17	Optional
Enhanced VMN	4.5.23	Optional
Enhanced VMN Ack	4.5.24	Optional

11 4.3.5.1 Enhanced Voice Mail Notification

12 The mobile station and voice mail system may support enhanced voice mail notification.

13 When enhanced voice mail notification is supported, the Enhanced VMN Subparameter is
14 sent in the Voice Mail Notification (see 4.3.5) when notifying the user of a new voice mail
15 message. The Enhanced VMN Subparameter includes information that enables a mobile
16 station to display details of a voice message to the user. The Enhanced VMN
17 Subparameter also includes information that enables the mobile station to automate the
18 playback of a voice mail message.

19 When enhanced voice mail notification is supported, the Enhanced VMN Ack
20 Subparameter is sent in the Voice Mail Notification (see 4.3.5) in order to acknowledge
21 voice mail messages that have been deleted by the user and to acknowledge voice mail
22 messages that have been played.

1 When either the Enhanced VMN Subparameter or the Enhanced VMN Ack Subparameter is
2 included in the voice mail notification, the Priority Indicator Subparameter shall not be
3 included.

4

4.3.6 Wireless Application Protocol (WAP)

The Wireless Application Protocol is described in [18]. This Teleservice uses the *SMS Deliver Message* and the *SMS Submit Message*. WAP is a point-to-point service only.

Table 4.3.6-1 and 4.3.6-2 list the subparameters used by WAP in the *SMS Deliver Message* and the *SMS Submit Message*. The MESSAGE_ID field of the Message Identifier subparameter shall be set as specified in Section 6.5.3 of [24]. The MSG_ENCODING field of the User Data subparameter shall be set to '00000'. The mobile station and message center may ignore parameters not listed in Table 4.3.6-1 and in Table 4.3.6-2.

Table 4.3.6-1. SMS Deliver Message Subparameters, WAP

Subparameter	Reference	Type
Message Identifier	4.5.1	Mandatory
User Data	4.5.2	Mandatory

Table 4.3.6-2. SMS Submit Message Subparameters, WAP

Subparameter	Reference	Type
Message Identifier	4.5.1	Mandatory
User Data	4.5.2	Mandatory

Since WAP is normally used for interactive sessions, and has provisions that ensure reliable message delivery when required, the message center should not store WAP messages that cannot be delivered immediately.

4.3.7 Wireless Enhanced Messaging Teleservice (WEMT)

The Wireless Enhanced Messaging Teleservice (WEMT) is used to carry Enhanced Messaging Service (EMS) over SMS. The EMS protocol is described in [21]. This Teleservice uses the *SMS Deliver Message*, and optionally the *SMS Submit Message*, the *SMS Cancellation Message*, the *SMS User Acknowledgment Message*, the *SMS Read Acknowledgment Message* and the *SMS Delivery Acknowledgment Message*. WEMT is a point-to-point service only.

Table 4.3.7-1 lists the subparameters used by WEMT in the *SMS Deliver Message*. The mobile station may ignore subparameters not listed in Table 4.3.7-1.

Table 4.3.7-1 SMS Deliver Message Subparameters, WEMT

Subparameter	Reference	Type
Message Identifier	4.5.1	Mandatory
User Data	4.5.2	Mandatory
Message Center Time Stamp	4.5.4	Optional
Validity Period – Absolute	4.5.5	Optional
Validity Period – Relative	4.5.6	Optional
Priority Indicator	4.5.9	Optional
Privacy Indicator	4.5.10	Optional
Reply Option	4.5.11	Optional
Number of Messages	4.5.12	Optional
Alert on Message Delivery	4.5.13	Optional
Language Indicator	4.5.14	Optional
Call-Back Number	4.5.15	Optional
Message Display Mode	4.5.16	Optional
Multiple Encoding User Data	4.5.17	Optional
Message Deposit Index	4.5.18	Optional

Table 4.3.7-2 lists the subparameters used by WEMT in the *SMS Submit Message*. The mobile station may ignore subparameters not listed in Table 4.3.7-2.

Table 4.3.7-2. SMS Submit Message Subparameters, WEMT

Subparameter	Reference	Type
Message Identifier	4.5.1	Mandatory
User Data	4.5.2	Mandatory
Validity Period – Absolute	4.5.5	Optional
Validity Period – Relative	4.5.6	Optional
Deferred Delivery Time – Absolute	4.5.7	Optional
Deferred Delivery Time – Relative	4.5.8	Optional
Priority Indicator	4.5.9	Optional
Privacy Indicator	4.5.10	Optional
Reply Option	4.5.11	Optional
Alert on Message Delivery	4.5.13	Optional
Language Indicator	4.5.14	Optional
Call-Back Number	4.5.15	Optional
Multiple Encoding User Data	4.5.17	Optional
Message Deposit Index	4.5.18	Optional

2

3 When the message center receives a WEMT *SMS Submit Message* whose destination is a
4 mobile station, the message center should use the contents of the *SMS Submit Message* to
5 form a WEMT *SMS Deliver Message* and send it to the destination mobile station.

6 When the message center receives an *SMS Cancellation Message* it should return an *SMS*
7 *Delivery Acknowledgment Message* with the User Data subparameter containing a message
8 indicating either cancellation of the submitted message or that the message has already
9 been delivered.

10 All subparameters of the *SMS User Acknowledgment Message*, listed in Table 4.4.4-1, may
11 be used by WEMT.

12 All subparameters of the *SMS Read Acknowledgment Message*, listed in Table 4.4.6-1, may
13 be used by WEMT.

14 All subparameters of the *SMS Delivery Acknowledgment Message*, listed in Table 4.4.5-1,
15 may be used by WEMT. This message is originated by the message center in response to
16 an *SMS Submit Message* with the DAK_REQ field set to '1'. The message center shall send
17 this message to the originating mobile station when the final destination confirms receipt of
18 the submitted message. If the final destination is a mobile station, the message center
19 should send the *SMS Delivery Acknowledgment Message* when informed that the
20 destination mobile station has returned a Transport Layer *SMS Acknowledgment Message*.
21 The message center may send the *SMS Delivery Acknowledgment Message* to indicate the
22 status of a message. The message center may include the User Data subparameter
23 containing a status message, the Message Status subparameter, or both. If both the User

1 Data subparameter and the Message Status subparameter are included in the message,
 2 and the mobile station supports the Message Status subparameter, the User Data
 3 subparameter may be ignored. The Message Center Time Stamp subparameter should
 4 contain the time at which the *SMS Delivery Acknowledgment Message* was sent.

5 The CHARi field of the subparameter User Data shall encapsulate GSM-SMS TP-User Data
 6 as defined in Section 9.2.3.24 of [21].

8 4.3.8 Service Category Programming Teleservice (SCPT)

9 The Service Category Programming Teleservice (SCPT) is used to add or remove Broadcast
 10 Service Categories in the mobile station profile. This Teleservice uses the *SMS Deliver*
 11 *Message* and optionally the *SMS Submit Message*. SCPT is a point-to-point service only.

12 Table 4.3.8-1 lists the subparameters used by SCPT in the *SMS Deliver Message*. The
 13 mobile station may ignore subparameters not listed in Table 4.3.8-1.

14
 15 **Table 4.3.8-1. SMS Deliver Message Subparameters, SCPT**

Subparameter	Reference	Type
Message Identifier	4.5.1	Mandatory
Message Center Time Stamp	4.5.4	Optional
Service Category Program Data	4.5.19	Mandatory

16
 17 Table 4.3.8-2 lists the subparameters used by SCPT in the *SMS Submit Message*. The
 18 message center may ignore subparameters not listed in Table 4.3.8-2.

19
 20 **Table 4.3.8-2. SMS Submit Message Subparameters, SCPT**

Subparameter	Reference	Type
Message Identifier	4.5.1	Mandatory
Service Category Program Results	4.5.20	Mandatory

21
 22 The SCPT *SMS Submit Message* may be originated by the mobile station in response to a
 23 SCPT *SMS Deliver Message* to indicate to the message center the results of the requested
 24 Service Category programming.

4.3.9 Card Application Toolkit Protocol Teleservice (CATPT)

The Card Application Toolkit Protocol Teleservice (CATPT) is used for data download to the R-UIM via SMS. This Teleservice uses the *SMS Deliver Message*, *SMS Submit Message* and the *SMS User Acknowledgment Message*. For detailed CATPT procedures see [25].

Table 4.3.9-1, 4.3.9-2 and 4.3.9-3 list the subparameters used by CATPT in the *SMS Deliver Message*, *SMS Submit Message* and the *SMS User Acknowledgment Message*. The mobile station and message center may ignore parameters not listed in Tables 4.3.9-1, Table 4.3.9-2 and 4.3.9-3.

Table 4.3.9-1. SMS Deliver Message Subparameters, CATPT

Subparameter	Reference	Type
Message Identifier	4.5.1	Mandatory
User Data	4.5.2	Mandatory

Table 4.3.9-2. SMS Submit Message Subparameters, CATPT

Subparameter	Reference	Type
Message Identifier	4.5.1	Mandatory
User Data	4.5.2	Mandatory

Table 4.3.9-3. SMS User Acknowledgment Message Subparameters, CATPT

Subparameter	Reference	Type
Message Identifier	4.5.1	Mandatory
User Data	4.5.2	Optional
User Response Code	4.5.3	Optional

4.4 Teleservice Message Contents

Teleservice messages are contained in the Bearer Data parameter of Transport Layer messages. The Teleservice message type is identified by the MESSAGE_TYPE field of the Message Identifier subparameter. The following sections list the subparameters that may be included in the Bearer Data parameter for each Teleservice message type.

4.4.1 SMS Deliver Message

The *SMS Deliver Message* may include the following Bearer Data subparameters.

Table 4.4.1-1. SMS Deliver Message Subparameters

Subparameter	Reference	Type
Message Identifier	4.5.1	Mandatory
User Data	4.5.2	Conditional (1)
Message Center Time Stamp	4.5.4	Conditional (1)
Validity Period – Absolute	4.5.5	Conditional (1)
Validity Period – Relative	4.5.6	Conditional (1)
Deferred Delivery Time – Absolute	4.5.7	Conditional (1)
Deferred Delivery Time – Relative	4.5.8	Conditional (1)
Priority Indicator	4.5.9	Conditional (1)
Privacy Indicator	4.5.10	Conditional (1)
Reply Option	4.5.11	Conditional (1)
Number of Messages	4.5.12	Conditional (1)
Alert on Message Delivery	4.5.13	Conditional (1)
Language Indicator	4.5.14	Conditional (1)
Call-Back Number	4.5.15	Conditional (1)
Message Display Mode	4.5.16	Conditional (1)
Multiple Encoding User Data	4.5.17	Conditional (1)
Message Deposit Index	4.5.18	Conditional (1)
Service Category Program Data	4.5.19	Conditional (1)
(1) Conditional means the field can be optional or mandatory depending on the Teleservice (see 4.3).		

10

11

1 4.4.2 SMS Submit Message

2 The *SMS Submit Message* may include the following Bearer Data subparameters.

3
4 **Table 4.4.2-1. SMS Submit Message Subparameters**

Subparameter	Reference	Type
Message Identifier	4.5.1	Mandatory
User Data	4.5.2	Conditional (1)
Validity Period – Absolute	4.5.5	Conditional (1)
Validity Period – Relative	4.5.6	Conditional (1)
Deferred Delivery Time - Absolute	4.5.7	Conditional (1)
Deferred Delivery Time - Relative	4.5.8	Conditional (1)
Priority Indicator	4.5.9	Conditional (1)
Privacy Indicator	4.5.10	Conditional (1)
Reply Option	4.5.11	Conditional (1)
Alert on Message Delivery	4.5.13	Conditional (1)
Language Indicator	4.5.14	Conditional (1)
Call-Back Number	4.5.15	Conditional (1)
Multiple Encoding User Data	4.5.17	Conditional (1)
Message Deposit Index	4.5.18	Conditional (1)
Service Category Program Results	4.5.20	Conditional (1)
(1) Conditional means the field can be optional or mandatory depending on the Teleservice (see 4.3).		

5

6

4.4.3 SMS Cancellation Message

The *SMS Cancellation Message* may include the following Bearer Data subparameter.

Table 4.4.3-1. SMS Cancellation Message Subparameters

Subparameter	Reference	Type
Message Identifier	4.5.1	Mandatory

4.4.4 SMS User Acknowledgment Message

The *SMS User Acknowledgment Message* may include the following Bearer Data subparameters.

Table 4.4.4-1. SMS User Acknowledgment Message Subparameters

Subparameter	Reference	Type
Message Identifier	4.5.1	Mandatory
User Data	4.5.2	Optional
User Response Code	4.5.3	Optional
Message Center Time Stamp	4.5.4	Optional
Multiple Encoding User Data	4.5.17	Optional
Message Deposit Index	4.5.18	Optional

4.4.5 SMS Delivery Acknowledgment Message

The *SMS Delivery Acknowledgment Message* may include the following Bearer Data subparameters. If both the User Data subparameter and the Message Status subparameter are included in the message, and the mobile station supports the Message Status subparameter, the User Data subparameter may be ignored.

Table 4.4.5-1. SMS Delivery Acknowledgment Message Subparameters

Subparameter	Reference	Type
Message Identifier	4.5.1	Mandatory
User Data	4.5.2	Optional
Message Center Time Stamp	4.5.4	Optional
Multiple Encoding User Data	4.5.17	Optional
Message Status	4.5.21	Optional

4.4.6 SMS Read Acknowledgment Message

The *SMS Read Acknowledgment Message* may include the following Bearer Data subparameters.

Table 4.4.6-1. SMS Read Acknowledgment Message Subparameters

Subparameter	Reference	Type
Message Identifier	4.5.1	Mandatory
User Data	4.5.2	Optional
Message Center Time Stamp	4.5.4	Optional
Multiple Encoding User Data	4.5.17	Optional
Message Deposit Index	4.5.18	Optional

4.4.7 SMS Deliver Report Message

The *SMS Deliver Report Message* may include the following Bearer Data subparameters.

Table 4.4.7-1. SMS Deliver Report Message Subparameters

Subparameter	Reference	Type
Message Identifier	4.5.1	Mandatory
TP-Failure Cause	4.5.22	Conditional
User Data	4.5.2	Optional
Language Indicator	4.5.14	Optional
Multiple Encoding User Data	4.5.17	Optional

4.4.8 SMS Submit Report Message

The *SMS Deliver Report Message* may include the following Bearer Data subparameters.

Table 4.4.8-1. SMS Submit Report Message Subparameters

Subparameter	Reference	Type
Message Identifier	4.5.1	Mandatory
TP-Failure Cause	4.5.22	Conditional
User Data	4.5.2	Optional
Language Indicator	4.5.14	Optional
Multiple Encoding User Data	4.5.17	Optional

4.5 Bearer Data Subparameters

The Bearer Data parameter of the Transport Layer message contains one or more of the following Bearer Data subparameters.

Table 4.5-1. Bearer Data Subparameter Identifiers

Subparameter	SUBPARAMETER_ID Value
Message Identifier	'00000000'
User Data	'00000001'
User Response Code	'00000010'
Message Center Time Stamp	'00000011'
Validity Period – Absolute	'00000100'
Validity Period – Relative	'00000101'
Deferred Delivery Time – Absolute	'00000110'
Deferred Delivery Time – Relative	'00000111'
Priority Indicator	'00001000'
Privacy Indicator	'00001001'
Reply Option	'00001010'
Number of Messages	'00001011'
Alert on Message Delivery	'00001100'
Language Indicator	'00001101'
Call-Back Number	'00001110'
Message Display Mode	'00001111'
Multiple Encoding User Data	'00010000'
Message Deposit Index	'00010001'
Service Category Program Data	'00010010'
Service Category Program Results	'00010011'
Message Status	'00010100'
TP-Failure Cause	'00010101'
Enhanced VMN	'00010110'
Enhanced VMN Ack	'00010111'
All other values are reserved.	

5

6

4.5.1 Message Identifier

The Message Identifier subparameter provides the message type and a message identification that can be used for acknowledgment. The Message Identifier subparameter has the following fixed-length format:

Field	Length (bits)
SUBPARAMETER_ID	8
SUBPARAM_LEN	8
MESSAGE_TYPE	4
MESSAGE_ID	16
HEADER_IND	1
RESERVED	3

SUBPARAMETER_ID - Subparameter identifier.

This field shall be set to '00000000'.

SUBPARAM_LEN - Subparameter length.

This field shall be set to '00000011'.

MESSAGE_TYPE - Message type.

The mobile station or base station shall set this field to the value from Table 4.5.1-1 identifying the message type.

1

Table 4.5.1-1. Message Types

MESSAGE_TYPE	Message Type
'0000'	Reserved
'0001'	Deliver (mobile-terminated only)
'0010'	Submit (mobile-originated only)
'0011'	Cancellation (mobile-originated only)
'0100'	Delivery Acknowledgment (mobile-terminated only)
'0101'	User Acknowledgment (either direction)
'0110'	Read Acknowledgment (either direction)
'0111'	Deliver Report (mobile-originated only)
'1000'	Submit Report (mobile-terminated only)
All other values are reserved.	

2

3

MESSAGE_ID - Message identifier.

4

The Teleservice end point shall set this field to the message identifier value for this message (see 4.3.1.5).

5

6

For Teleservices that do not require message identifiers this field should be set to 0x0000.

7

8

HEADER_IND - Header Indicator.

9

If the User Data Subparameter includes the User Data Header [21], this field shall be set to '1'. Otherwise this field shall be set to '0'.

10

11

12

If this field is set to '1', the CHARi field in the User Data Subparameter contains a User Data Header as defined in 9.2.3.4 of [21], beginning with the first octet.

13

14

15

16

RESERVED - Reserved bits.

17

All bits of this field shall be set to zeros.

18

4.5.2 User Data

The User Data subparameter has the following variable-length format:

Field	Length (bits)
SUBPARAMETER_ID	8
SUBPARAM_LEN	8
MSG_ENCODING	5
MESSAGE_TYPE	0 or 8
NUM_FIELDS	8

NUM_FIELDS occurrences of the following field:

CHAR _i	Variable - see [15]
-------------------	---------------------

The subparameter ends with the following field:

RESERVED	0-7
----------	-----

- 4
- 5 SUBPARAMETER_ID - Subparameter identifier.
- 6 This field shall be set to '00000001'.
- 7 SUBPARAM_LEN - Subparameter length.
- 8 This field shall be set to the number of octets in the
- 9 subparameter, not including the SUBPARAMETER_ID
- 10 and SUBPARAM_LEN fields.
- 11 MSG_ENCODING - Message encoding.
- 12 See [15].
- 13 Support of an encoding method does not imply that
- 14 the entire encodable character set needs to be
- 15 supported. In general, once the supported character
- 16 set is determined, various subsets of the character
- 17 set can be supported. If a message is comprised entirely
- 18 of characters from a supported subset of a character
- 19 set, it can be displayed. If a message contains an
- 20 unsupported character of a character set, it can be
- 21 discarded.
- 22 MESSAGE_TYPE - Message type.
- 23 If the MSG_ENCODING field is set to '00001' (IS-91
- 24 Extended Protocol Message), this field shall be set to
- 25 the IS-91 Extended Protocol Message Type, as defined
- 26 in Table 9 of [14]. If the MSG_ENCODING field is set
- 27 to '01010' (GSM Data-Coding-Scheme), this field shall

1			be set to the SMS Data Coding Scheme, as defined in
2			Section 4 of [20].
3			Otherwise, this field shall be omitted.
4	NUM_FIELDS	-	Number of fields.
5			If the MSG_ENCODING field is set to '00101' (Shift-
6			JIS) or '00110' (Korean), this field indicates the total
7			length in bytes of the CHARi field; otherwise this field
8			shall be set to the number of characters included in
9			this subparameter.
10	CHARi	-	Character or, if the Teleservice is WEMT, encapsulated
11			GSM-SMS TP User Data as defined in Section 9.2.3.24
12			of [21].
13			This subparameter shall include NUM_FIELDS
14			occurrences of this field.
15	RESERVED	-	Reserved bits.
16			This field shall contain the number of bits required to
17			make the entire subparameter an integer number of
18			octets in length. All bits of this field shall be set to
19			zeros.
20			

4.5.3 User Response Code

The User Response Code subparameter is used in the *SMS User Acknowledgment Message* to respond to previously received short messages. This message center-specific element carries the identifier of a predefined response.

The User Response Code subparameter has the following fixed-length format:

Field	Length (bits)
SUBPARAMETER_ID	8
SUBPARAM_LEN	8
RESPONSE_CODE	8

SUBPARAMETER_ID - Subparameter identifier.

This field shall be set to '00000010'.

SUBPARAM_LEN - Subparameter length.

This field shall be set to '00000001'.

RESPONSE_CODE - Response code.

This field shall be set to the value selected by the Teleservice. The meaning of this field is defined by the Teleservice and the SMS message center.

4.5.4 Message Center Time Stamp

The Message Center Time Stamp subparameter may be included with SMS messages sent from a Message Center. If the subscriber is configured to use UTC SMS timestamp mode, the time in this subparameter shall be set to UTC time. If the subscriber is configured to use non-UTC SMS timestamp mode, the time in this subparameter shall be set to the time to be displayed at the mobile station. See 3.4.29 of [19] for R-UIM equipped mobile stations.

The Message Center Time Stamp subparameter has the following fixed-length format:

Field	Length (bits)
SUBPARAMETER_ID	8
SUBPARAM_LEN	8
YEAR	8
MONTH	8
DAY	8
HOURS	8
MINUTES	8
SECONDS	8
Note: all date and time fields contain two 4-bit BCD numbers giving the decimal value of the field. For example, if the year is 1996, the YEAR field contains '10010110'.	

SUBPARAMETER_ID - Subparameter identifier.

This field shall be set to '00000011'.

SUBPARAM_LEN - Subparameter length.

This field shall be set to '00000110'.

YEAR - Current year.

This field shall be set to the current year, in the range 00-99.¹²

MONTH - Current month.

¹² When performing computations with the value of the field YEAR, the value should be converted to the full year in the range 1996-2095 by adding 1900 if the value is between 96 and 99 inclusive or by adding 2000 if the value is between 00 and 95 inclusive; e.g., 99 should be converted to 1999 and 00 to 2000.

1			This field shall be set to the current month, in the
2			range 1-12.
3	DAY	-	Current day of month.
4			This field shall be set to the current day of the month.
5	HOURS	-	Current hour.
6			This field shall be set to the current hour, in the range
7			0-23.
8	MINUTES	-	Current minutes.
9			This field shall be set to the current minutes, in the
10			range 0-59.
11	SECONDS	-	Current seconds.
12			This field shall be set to the current seconds, in the
13			range 0-59.
14			

4.5.5 Validity Period - Absolute

The Validity Period - Absolute subparameter indicates to the message center the message expiration time, after which the message should be discarded if not delivered to the destination. If the subscriber is configured to use UTC SMS timestamp mode, the time in this subparameter shall be set to UTC time. If the subscriber is configured to use non-UTC SMS timestamp mode, the time in this subparameter shall be set according to the time displayed at the mobile station. See 3.4.29 of [19] for R-UIM equipped mobile stations.

The Validity Period - Absolute subparameter has the following fixed-length format:

Field	Length (bits)
SUBPARAMETER_ID	8
SUBPARAM_LEN	8
YEAR	8
MONTH	8
DAY	8
HOURS	8
MINUTES	8
SECONDS	8
Note: all date and time fields contain two 4-bit BCD numbers giving the decimal value of the field. For example, if the year is 1996, the YEAR field contains '10010110'.	

10

11 SUBPARAMETER_ID - Subparameter identifier.

12 This field shall be set to '00000100'.

13 SUBPARAM_LEN - Subparameter length.

14 This field shall be set to '00000110'.

15 YEAR - Expiration year.

16 This field shall be set to the expiration year, in the
17 range 00-99¹³.

18 MONTH - Expiration month.

¹³ When performing computations with the value of the field YEAR, the value should be converted to the full year in the range 1996-2095 by adding 1900 if the value is between 96 and 99 inclusive or by adding 2000 if the value is between 00 and 95 inclusive; e.g., 99 should be converted to 1999 and 00 to 2000.

1			This field shall be set to the expiration month, in the
2			range 1-12.
3	DAY	-	Expiration day of month.
4			This field shall be set to the expiration day of the
5			month.
6	HOURS	-	Expiration hour.
7			This field shall be set to the expiration hour, in the
8			range 0-23.
9	MINUTES	-	Expiration minutes.
10			This field shall be set to the expiration minutes in the
11			range 0-59.
12	SECONDS	-	Expiration seconds.
13			This field shall be set to the expiration seconds, in the
14			range 0-59.
15			

1 4.5.6 Validity Period - Relative

2 The Validity Period - Relative subparameter indicates to the message center the time
 3 period, beginning from the time the message is received by the message center, after which
 4 the message should be discarded if not delivered to the destination. May also be used to
 5 indicate the time period to retain a message sent to a mobile station.

6 The Validity Period - Relative subparameter has the following fixed-length format:

7

Field	Length (bits)
SUBPARAMETER_ID	8
SUBPARAM_LEN	8
VALIDITY	8

8
 9 SUBPARAMETER_ID - Subparameter identifier.

10 This field shall be set to '00000101'.

11 SUBPARAM_LEN - Subparameter length.

12 This field shall be set to '00000001'.

13 VALIDITY - Validity period.

14 This field shall be set according to Table 4.5.6-1.

15

1

Table 4.5.6-1. Coding of Relative Time Fields

Field value (decimal)	Relative Time Period	Validity Period	Delivery Time
0 to 143	$(\text{value} + 1) \times 5$ minutes	X	X
144 to 167	12 hours + $((\text{value} - 143) \times 30)$ minutes	X	X
168 to 196	$(\text{value} - 166)$ days	X	X
197 to 244	$(\text{value} - 192)$ weeks	X	X
245	Indefinite	X	
246	Immediate (1)	X	
247	Valid until mobile becomes inactive/ Deliver when mobile next becomes active	X	X
248	Valid until registration area changes, discard if not registered	X	
249 to 255	Reserved		
(1) Indicates that the message should be discarded if not immediately deliverable. If this value is present in a message received by a mobile station, the mobile station should discard the message after it has been displayed.			

2

4.5.7 Deferred Delivery Time - Absolute

The Deferred Delivery Time - Absolute subparameter indicates the absolute time of delivery desired by the originator. If the subscriber is configured to use UTC SMS timestamp mode, the time in this subparameter shall be set to UTC time. If the subscriber is configured to use non-UTC SMS timestamp mode, the time in this subparameter shall be set according to the time displayed at the mobile station. See 3.4.29 of [19] for R-UIM equipped mobile stations.

The Deferred Delivery Time - Absolute subparameter has the following fixed-length format:

Field	Length (bits)
SUBPARAMETER_ID	8
SUBPARAM_LEN	8
YEAR	8
MONTH	8
DAY	8
HOURS	8
MINUTES	8
SECONDS	8
Note: all date and time fields contain two 4-bit BCD numbers giving the decimal value of the field. For example, if the year is 1996, the YEAR field contains '10010110'.	

SUBPARAMETER_ID - Subparameter identifier.

This field shall be set to '00000110'.

SUBPARAM_LEN - Subparameter length.

This field shall be set to '00000110'.

YEAR - Delivery year.

This field shall be set to the delivery year, in the range 00-99.¹⁴

MONTH - Delivery month.

¹⁴ When performing computations with the value of the field YEAR, the value should be converted to the full year in the range 1996-2095 by adding 1900 if the value is between 96 and 99 inclusive or by adding 2000 if the value is between 00 and 95 inclusive; e.g., 99 should be converted to 1999 and 00 to 2000.

1			This field shall be set to the delivery month, in the
2			range 1-12.
3	DAY	-	Delivery day of month.
4			This field shall be set to the delivery day of the month.
5	HOURS	-	Delivery hour.
6			This field shall be set to the delivery hour, in the range
7			0-23.
8	MINUTES	-	Delivery minutes.
9			This field shall be set to the delivery minutes, in the
10			range 0-59.
11	SECONDS	-	Current seconds.
12			This field shall be set to the delivery seconds, in the
13			range 0-59.
14			

1 4.5.8 Deferred Delivery Time - Relative

2 The Deferred Delivery Time - Relative subparameter indicates the relative time of delivery
3 desired by the sender. Indicates the time period, beginning from the time the message is
4 received by the message center, after which the message should be delivered.

5 The Deferred Delivery Time - Relative subparameter has the following fixed-length format:

6

Field	Length (bits)
SUBPARAMETER_ID	8
SUBPARAM_LEN	8
DELIVERY_TIME	8

7

8 SUBPARAMETER_ID - Subparameter identifier.

9 This field shall be set to '00000111'.

10 SUBPARAM_LEN - Subparameter length.

11 This field shall be set to '00000001'.

12 DELIVERY_TIME - Deferred delivery time period.

13 This field shall be set according to Table 4.5.6-1.

14

4.5.9 Priority Indicator

The Priority Indicator subparameter indicates the priority level of the message.

The Priority Indicator subparameter has the following fixed-length format:

Field	Length (bits)
SUBPARAMETER_ID	8
SUBPARAM_LEN	8
PRIORITY	2
RESERVED	6

SUBPARAMETER_ID - Subparameter identifier.

This field shall be set to '00001000'.

SUBPARAM_LEN - Subparameter length.

This field shall be set to '00000001'.

PRIORITY - Level of priority.

This field shall be set according to Table 4.5.9-1.

Table 4.5.9-1. Priority Indicator Values

PRIORITY	Level of Priority
'00'	Normal
'01'	Interactive
'10'	Urgent
'11'	Emergency

RESERVED - Reserved bits.

All bits of this field shall be set to zeros.

1 4.5.10 Privacy Indicator

2 The Privacy Indicator subparameter indicates the desired privacy level of the message.

3 The Privacy Indicator subparameter has the following fixed-length format:

4

Field	Length (bits)
SUBPARAMETER_ID	8
SUBPARAM_LEN	8
PRIVACY	2
RESERVED	6

5
6 SUBPARAMETER_ID - Subparameter identifier.

7 This field shall be set to '00001001'.

8 SUBPARAM_LEN - Subparameter length.

9 This field shall be set to '00000001'.

10 PRIVACY - Privacy level.

11 This field shall be set according to Table 4.5.10-1.

12
13 **Table 4.5.10-1. Privacy Indicator Values**

PRIVACY	Level of Privacy
'00'	Not restricted (privacy level 0)
'01'	Restricted (privacy level 1)
'10'	Confidential (privacy level 2)
'11'	Secret (privacy level 3)

14
15 RESERVED - Reserved bits.

16 All bits of this field shall be set to zeros.

4.5.11 Reply Option

The Reply Option subparameter indicates whether SMS acknowledgment is requested or not requested. This subparameter should not be included in the message with USER_ACK_REQ, DAK_REQ and READ_ACK_REQ all set to '0'.

The Reply Option subparameter has the following fixed-length format:

Field	Length (bits)
SUBPARAMETER_ID	8
SUBPARAM_LEN	8
USER_ACK_REQ	1
DAK_REQ	1
READ_ACK_REQ	1
REPORT_REQ	1
RESERVED	4

- 7
- 8 SUBPARAMETER_ID - Subparameter identifier.
- 9 This field shall be set to '00001010'.
- 10 SUBPARAM_LEN - Subparameter length.
- 11 This field shall be set to '00000001'.
- 12 USER_ACK_REQ - Positive user (manual) acknowledgment requested.
- 13 When a user (manual) acknowledgment is requested
- 14 as acknowledgment of message delivery, this field shall
- 15 be set to '1'; otherwise, this field shall be set to '0'.
- 16 DAK_REQ - Delivery acknowledgment request.
- 17 In a mobile-originated message, when delivery
- 18 acknowledgment is requested, this field shall be set to
- 19 '1'; otherwise, this field shall be set to '0'.
- 20 This field shall be set to '0' in all mobile-terminated
- 21 SMS messages.
- 22 READ_ACK_REQ - Read acknowledgment request.
- 23 When a read acknowledgment is requested as
- 24 acknowledgment of the message being viewed, this
- 25 field shall be set to '1'; otherwise, this field shall be set
- 26 to '0'.
- 27 REPORT_REQ - Delivery report request.

1 In a mobile-originated message, when a delivery report
2 is requested, this field shall be set to '1'; otherwise,
3 this field shall be set to '0'.

4 In a mobile-terminated message, when a submit report
5 is requested, this field shall be set to '1'; otherwise,
6 this field shall be set to '0'.

7 RESERVED - Reserved bits.

8 All bits of this field shall be set to zeros.

9

4.5.12 Number of Messages

The Number of Messages element is a decimal number in the 0 to 99 range representing the number of messages stored at the Voice Mail System. This element is used by the Voice Mail Notification service.

The Number of Messages subparameter has the following fixed-length format:

Field	Length (bits)
SUBPARAMETER_ID	8
SUBPARAM_LEN	8
MESSAGE_CT	8

- SUBPARAMETER_ID - Subparameter identifier.
This field shall be set to '00001011'.
- SUBPARAM_LEN - Subparameter length.
This field shall be set to '00000001'.
- MESSAGE_CT - Message count.
This field shall be set to the number of messages stored at the Voice Mail System, in the range 0-99.
This field shall contain two 4-bit BCD numbers giving the decimal value of the field. For example, if the number of messages is 93, the MESSAGE_CT field contains '10010011'.

4.5.13 Alert on Message Delivery

The Alert on Message Delivery subparameter indicates that alerting is requested. Such methods as vibrating and sound may be used.

The Alert on Message Delivery subparameter has the following fixed-length format:

Field	Length (bits)
SUBPARAMETER_ID	8
SUBPARAM_LEN	8
ALERT_PRIORITY	2
RESERVED	6

SUBPARAMETER_ID - Subparameter identifier.

This field shall be set to '00001100'.

SUBPARAM_LEN - Subparameter length.

This field shall be set to '00000001'.

ALERT_PRIORITY - The type of alerts used to distinguish different priorities of the message.

Table 4.5.13-1. ALERT_PRIORITY Values

ALERT_PRIORITY	Function
'00'	Use Mobile default alert
'01'	Use Low-priority alert (1)
'10'	Use Medium-priority alert (1)
'11'	Use High-priority alert (1)
(1) This alert is defined by the mobile station.	

RESERVED - Reserved bits.

All bits of this field shall be set to zeros.

4.5.14 Language Indicator

The Language Indicator subparameter indicates the language of the message so that the receiving mobile station can discard those messages that are not in the user's preferred language.

The Language Indicator subparameter has the following fixed-length format:

Field	Length (bits)
SUBPARAMETER_ID	8
SUBPARAM_LEN	8
LANGUAGE	8

SUBPARAMETER_ID - Subparameter identifier.

This field shall be set to '00001101'.

SUBPARAM_LEN - Subparameter length.

This field shall be set to '00000001'.

LANGUAGE - Language used for message text.

This field shall be set to the appropriate value as shown in [15].

4.5.15 Call-Back Number

The Call-Back Number subparameter indicates the number to be dialed in reply to a received SMS message.

For Teleservices such as wireless paging and voice mail notification, this subparameter is typically set to the number of the originating party.

When used in the context of a Broadcast Messaging Service Teleservice, this subparameter indicates a third-party call-back number to be dialed in reply to a received *SMS Broadcast Message*.

The Call-Back Number subparameter has the following variable-length format:

Field	Length (bits)
SUBPARAMETER_ID	8
SUBPARAM_LEN	8
DIGIT_MODE	1
NUMBER_TYPE	0 or 3
NUMBER_PLAN	0 or 4
NUM_FIELDS	8

NUM_FIELDS occurrences of the following field:

CHAR _i	4 or 8
-------------------	--------

The subparameter ends with the following field:

RESERVED	0-7
----------	-----

SUBPARAMETER_ID - Subparameter identifier.

This field shall be set to '00001110'.

SUBPARAM_LEN - Subparameter length.

This field shall be set to the number of octets in the subparameter, not including the SUBPARAMETER_ID and SUBPARAM_LEN fields.

DIGIT_MODE - Digit mode indicator.

This field indicates whether the call-back number digits are 4-bit DTMF codes or 8-bit ASCII codes.

To specify the call-back number using the binary representation of DTMF digits, this field shall be set to '0'. To specify the call-back number using ASCII characters, this field shall be set to '1'.

1	NUMBER_TYPE	-	Type of number.
2			If the DIGIT_MODE field is set to '1', this field shall be
3			set to the NUMBER_TYPE value shown in [10] Table
4			2.7.1.3.2.4-2 corresponding to the type of the number
5			as defined in [6]. If the DIGIT_MODE field is set to '0',
6			this field shall be omitted.
7	NUMBER_PLAN	-	Numbering plan.
8			If the DIGIT_MODE field is set to '1', this field shall be
9			set to the NUMBER_PLAN value shown in [10] Table
10			2.7.1.3.2.4-3 corresponding to the requested
11			numbering plan. If the DIGIT_MODE field is set to '0',
12			this field shall be omitted.
13	NUM_FIELDS	-	Number of call-back number digits in this
14			subparameter.
15			This field shall be set to the number of call-back
16			number digits included in this subparameter.
17	CHARi	-	A call-back number digit or character.
18			This subparameter shall include NUM_FIELDS
19			occurrences of this field. If the DIGIT_MODE field is
20			set to '0', each occurrence of this field shall be set to
21			the code value shown in [10] Table 2.7.1.3.2.4-4
22			corresponding to the call-back number digit. If the
23			DIGIT_MODE field is set to '1', each occurrence of this
24			field shall be set to the ASCII representation
25			corresponding to the call-back number digit, as
26			specified in [7], with the most significant bit set to '0'.
27	RESERVED	-	Reserved bits.
28			This field shall contain the number of bits required to
29			make the entire subparameter an integer number of
30			octets in length. All bits of this field shall be set to
31			zeros.
32			

4.5.16 Message Display Mode

The Message Display Mode subparameter is used to indicate to the mobile station when to display the received message. The Message Display Mode subparameter has the following fixed-length format:

Field	Length (bits)
SUBPARAMETER_ID	8
SUBPARAM_LEN	8
MSG_DISPLAY_MODE	2
RESERVED	6

SUBPARAMETER_ID - Subparameter identifier.

This field shall be set to '00001111'.

SUBPARAM_LEN - Subparameter length.

This field shall be set to '00000001'.

MSG_DISPLAY_MODE- Message display mode.

This field shall be set according to Table 4.5.16-1.

Table 4.5.16-1. Message Display Mode Indicator Values

MSG_DISPLAY_MODE	Function
'00'	Immediate Display: The mobile station is to display the received message as soon as possible.
'01'	Mobile default setting: The mobile station is to display the received message based on a pre-defined mode in the mobile station.
'10'	User Invoke: The mobile station is to display the received message based on the mode selected by the user.
'11'	Reserved

RESERVED - Reserved bits.

All bits of this field shall be set to zeros.

4.5.17 Multiple Encoding User Data

The Multiple Encoding User Data subparameter has the following variable-length format:

Field	Length (bits)
SUBPARAMETER_ID	8
SUBPARAM_LEN	8

One or more occurrences of the following encoding-specific fields

Encoding-specific fields	Variable
--------------------------	----------

The subparameter ends with the following field:

RESERVED	0-7
----------	-----

SUBPARAMETER_ID - Subparameter identifier.

This field shall be set to '00010000'.

SUBPARAM_LEN - Subparameter length.

This field shall be set to the number of octets in the subparameter, not including the SUBPARAMETER_ID and SUBPARAM_LEN fields.

Encoding-specific fields- Encoding-specific fields.

Encoding-specific fields shall include the following fields:

Field	Length (bits)
MSG_ENCODING	5
NUM_FIELDS	8

NUM_FIELDS occurrences of the following field

CHAR _i	Variable - see [15]
-------------------	---------------------

MSG_ENCODING - Message encoding.

See [15].

Support of an encoding method does not imply that the entire encodable character set needs to be supported. In general, once the supported character set is determined, various subsets of the character set can be supported. If a message is comprised entirely

1			of characters from a supported subset of a character
2			set, it can be displayed. If a message contains an
3			unsupported character of a character set, it can be
4			discarded.
5	NUM_FIELDS	-	Number of fields.
6			If the MSG_ENCODING field is set to '00101' (Shift-
7			JIS) or '00110' (Korean), this field indicates the total
8			length in bytes of the CHARi field; otherwise this field
9			shall be set to the number of characters included in
10			this occurrence of the encoding-specific-fields.
11	CHARi	-	Character.
12			Each occurrence of the encoding-specific-fields shall
13			include NUM_FIELDS occurrences of this field.
14	RESERVED	-	Reserved bits.
15			This field shall contain the number of bits required to
16			make the entire subparameter an integer number of
17			octets in length. All bits of this field shall be set to
18			zeros.
19			

4.5.18 Message Deposit Index

The Message Deposit Index subparameter is assigned by the message center as a unique index to the contents of the User Data subparameter in each message sent to a particular mobile station. The mobile station, when replying to a previously received short message which included a Message Deposit Index subparameter, may include the Message Deposit Index of the received message to indicate to the message center that the original contents of the message are to be included in the reply.

The Message Deposit Index subparameter has the following fixed-length format:

Field	Length (bits)
SUBPARAMETER_ID	8
SUBPARAM_LEN	8
MESSAGE_DEPOSIT_INDEX	16

SUBPARAMETER_ID - Subparameter identifier.

This field shall be set to '00010001'.

SUBPARAM_LEN - Subparameter length.

This field shall be set to '00000010'.

MESSAGE_DEPOSIT_INDEX - Message deposit index.

This field contains the index used by the message center to uniquely identify a short message.

4.5.19 Service Category Program Data

The Service Category Program Data subparameter is used to enable or disable SMS Broadcast Service Categories in the mobile station.

The Service Category Program Data subparameter has the following variable-length format:

Field	Length (bits)
SUBPARAMETER_ID	8
SUBPARAM_LEN	8
MSG_ENCODING	5

One or more occurrences of the Category-specific fields:

Category-specific fields	Variable
--------------------------	----------

The subparameter ends with the following field:

RESERVED	0-7
----------	-----

SUBPARAMETER_ID - Subparameter identifier.

This field shall be set to '00010010'.

SUBPARAM_LEN - Subparameter length.

This field shall be set to the number of octets in the subparameter, not including the SUBPARAMETER_ID and SUBPARAM_LEN fields.

MSG_ENCODING - Message encoding.

See [15]. This field shall be set to indicate the character set used in the Category-specific fields included in this subparameter.

Support of an encoding method does not imply that the entire encodable character set needs to be supported. In general, once the supported character set is determined, various subsets of the character set can be supported. If a message is comprised entirely of characters from a supported subset of a character set, it can be displayed. If a message contains an unsupported character of a character set, it can be discarded.

Category-specific fields- Category-specific fields

Category-specific fields shall include the following fields:

1

Field	Length (bits)
OPERATION_CODE	4
CATEGORY	16
LANGUAGE	8
MAX_MESSAGES	8
ALERT_OPTION	4
NUM_FIELDS	8

NUM_FIELDS occurrences of the following field

CHARi	Variable - see [15]
-------	---------------------

2

3

OPERATION_CODE - Operation Code.

4

This field shall be set to '0000' to delete the Service Category. The Service Category identified in the CATEGORY field shall be removed from the mobile station profile. Removal from the mobile station profile means that the mobile station shall discard all Broadcast SMS messages received with the indicated Service Category, as specified in Section 2.4.1.2.1.

5

6

7

8

9

10

11

This field shall be set to '0001' to add the Service Category. The Service Category identified in the CATEGORY field shall be added to the mobile station profile. Adding to the mobile station profile means that the mobile station should process all Broadcast SMS messages received with the indicated Service Category, as specified in Section 2.4.1.2.1.

12

13

14

15

16

17

This field shall be set to '0010' to clear all Service Categories. All of the Service Categories contained in the mobile station profile shall be deleted. The CATEGORY, MAX_MESSAGES, ALERT_OPTION and CATEGORY_NAME fields shall be ignored.

18

19

20

21

22

All other values are reserved.

23

24

CATEGORY - Broadcast Service Category.

25

This field shall be set according to [15]. This field contains the value of the Service Category for the operation.

26

27

28

LANGUAGE - Language used for message text.

29

This field shall be set to the appropriate value as shown in [15].

30

1
2
3
4
5
6
7
8
9
10
11

Each occurrence of the Category-specific fields shall include NUM_FIELDS occurrences of this field.

If a Category Service name contains an unsupported character of a character set, this entire CHARi field set can be discarded.

RESERVED

-

Reserved bits.

This field shall contain the number of bits required to make the entire subparameter an integer number of octets in length. All bits of this field shall be set to zeros.

1 4.5.20 Service Category Program Results

2 The Service Category Program Results subparameter is used to inform the message center
3 of the results of a request to program SMS Broadcast Service Categories in the mobile
4 station.

5 The Service Category Program Results subparameter has the following variable-length
6 format:

Field	Length (bits)
SUBPARAMETER_ID	8
SUBPARAM_LEN	8

7 One or more occurrences of the following fields:

CATEGORY	16
CATEGORY_RESULT	4
RESERVED	4

8
9 SUBPARAMETER_ID - Subparameter identifier.

10 This field shall be set to '00010011'.

11 SUBPARAM_LEN - Subparameter length.

12 This field shall be set to the number of octets in the
13 subparameter, not including the SUBPARAMETER_ID
14 and SUBPARAM_LEN fields.

15 CATEGORY - Broadcast Service Category.

16 This field shall be set according to [15]. This field
17 contains the value of the Service Category for the
18 operation.

19 CATEGORY_RESULT - Service Category programming result.

20 This field shall be set according to Table 4.5.20-1.

1

Table 4.5.20-1. Service Category Program Result Codes

Result Code	Result
'0000'	Programming successful
'0001'	Service Category memory limit exceeded
'0010'	Service Category limit exceeded
'0011'	Category already programmed
'0100'	Category not previously programmed
'0101'	Invalid MAX_MESSAGES
'0110'	Invalid ALERT_OPTION
'0111'	Invalid Service Category name
'1000'	Unspecified programming failure
All other values reserved.	

2

3

RESERVED - Reserved bits.

4

All bits of this field shall be set to zeros.

5

4.5.21 Message Status

The Message Status subparameter provides an indication of the status of a message or if an SMS error has occurred, the nature of the error and whether the condition is considered temporary or permanent.

The Message Status parameter has the following variable-length format:

Field	Length (bits)
SUBPARAMETER_ID	8
SUBPARAM_LEN	8
ERROR_CLASS	2
MSG_STATUS_CODE	6

- 7
- 8 SUBPARAMETER_ID - Subparameter identifier.
- 9 This field shall be set to '00010100'.
- 10 SUBPARAM_LEN - Subparameter length.
- 11 This field shall be set to the number of octets in the
- 12 subparameter, not including the SUBPARAMETER_ID
- 13 and SUBPARAM_LEN fields.
- 14 ERROR_CLASS - Error report class.
- 15 If there is no error, this field shall be set to '00'.
- 16 If the error is caused by a temporary condition, this
- 17 field shall be set to '10'. If the error is caused by a
- 18 permanent condition, this field shall be set to '11'.
- 19 The value '01' is reserved.
- 20 MSG_STATUS_CODE - Message status code.
- 21 This field shall be set to the appropriate SMS Message
- 22 Status Code, as defined in Table 4.5.21-1.
- 23

1

Table 4.5.21-1. SMS Message Status Codes

Status Code	Message Status
ERROR_CLASS = '00' (no error)	
'000000'	Message accepted
'000001'	Message deposited to Internet
'000010'	Message delivered
'000011'	Message cancelled
ERROR_CLASS = '10' (temporary condition)	
'000100'	Network congestion
'000101'	Network error
'011111'	Unknown error
ERROR_CLASS = '11' (permanent condition)	
'000100'	Network congestion
'000101'	Network error
'000110'	Cancel failed
'000111'	Blocked destination
'001000'	Text too long
'001001'	Duplicate message
'001010'	Invalid destination
'001101'	Message expired
'011111'	Unknown error
All other values reserved.	

2

3

1 4.5.22 TP-Failure Cause

2 The TP-Failure Cause value.

3 The TP-Failure Cause parameter has the following fixed-length format:

4

Field	Length (bits)
SUBPARAMETER_ID	8
SUBPARAM_LEN	8
VALUE	8

5

6 SUBPARAMETER_ID - Subparameter identifier.

7 This field shall be set to '00010101'.

8 SUBPARAM_LEN - Subparameter length.

9 This field shall be set to '00000001'.

10 VALUE - TP-Failure Cause value.

11 This field shall be set to the GSM-SMS TP-Failure
12 Cause as defined in Section 9.2.3.22 of [21].
13

- 1 4.5.23 Enhanced VMN
- 2 The Enhanced VMN subparameter includes enhanced VMN information.
- 3 The Enhanced VMN subparameter has the following variable-length format:

Field	Length (bits)
SUBPARAMETER_ID	8
SUBPARAM_LEN	8
PRIORITY_INDICATION	2
PASSWORD_REQUIRED	1
SETUP_REQUIRED	1
PASSWORD_CHANGE_REQUIRED	1
MIN_PASSWORD_LEN	0 or 4
MAX_PASSWORD_LEN	0 or 4
VM_NUM_UNHEARD_MESSAGES	8
VM_MAILBOX_ALMOST_FULL	1
VM_MAILBOX_FULL	1
REPLY_ALLOWED	1
FAX_INCLUDED	1
VM_LENGTH	12
VM_RETENTION_DAYS	7
VM_MESSAGE_ID	16
VM_MAILBOX_ID	16
AN_DIGIT_MODE	1
AN_NUMBER_TYPE	3
AN_NUMBER_PLAN	0 or 4
AN_NUM_FIELDS	8

AN_NUM_FIELDS occurrences of the following field:

AN_CHAR _i	4 or 8
----------------------	--------

CLI_DIGIT_MODE	1
CLI_NUMBER_TYPE	3
CLI_NUMBER_PLAN	0 or 4
CLI_NUM_FIELDS	8

CLI_NUM_FIELDS occurrences of the following field:

CLI_CHAR _i	4 or 8
-----------------------	--------

The subparameter ends with the following field:

RESERVED	0-7
----------	-----

1	SUBPARAMETER_ID -	Subparameter identifier.
2		This field shall be set to '00010110'.
3	SUBPARAM_LEN -	Subparameter length.
4		This field shall be set to the number of octets in the
5		subparameter, not including the SUBPARAMETER_ID
6		and SUBPARAM_LEN fields.
7	PRIORITY_INDICATION -	Priority indication.
8		This field shall be set according to Table 4.5.9-1.
9	PASSWORD_REQUIRED -	Password required flag.
10		This field shall be set to '1' if a password is required by
11		the voice mailbox associated with the voice mail
12		message; otherwise this field shall be set to '0'.
13	SETUP_REQUIRED -	Setup required flag.
14		This field shall be set to '1' if the mobile station is to
15		prompt the user for initial setup of greeting, password,
16		and recorded name; otherwise this field shall be set to
17		'0'.
18	PASSWORD_CHANGE_REQUIRED -	Password change required flag.
19		This field shall be set to '1' if the user is required to
20		change the password before playing the voice mail
21		message; otherwise this field shall be set to '0'.
22	MIN_PASSWORD_LEN -	Minimum Password length.
23		If SETUP_REQUIRED is equal to '0' and
24		PASSWORD_CHANGE_REQUIRED is equal to '0', this
25		field shall not be included; otherwise, this field shall
26		be included and shall be set as follows.
27		This field shall be set to the minimum number of digits
28		required in the password.
29	MAX_PASSWORD_LEN -	Maximum Password length.
30		If SETUP_REQUIRED is equal to '0' and
31		PASSWORD_CHANGE_REQUIRED is equal to '0', this
32		field shall not be included; otherwise, this field shall
33		be included and shall be set as follows.
34		This field shall be set to the maximum number of
35		digits required in the password.
36	VM_NUM_UNHEARD_MESSAGES -	Number of Unheard Voice Mail Messages.

1		This field shall be set to the number of unheard voice
2		mail messages stored at the Voice Mail System, in the
3		range 0-255.
4	VM_MAILBOX_ALMOST_FULL	- Voice Mailbox almost full flag.
5		This field shall be set to '1' if the mailbox in the voice
6		mail system is almost full; otherwise this field shall be
7		set to '0'. The point at which the voice mailbox is
8		considered almost full is left to the discretion of the
9		operator.
10	VM_MAILBOX_FULL	- Voice Mailbox full flag.
11		This field shall be set to '1' if the mailbox in the voice
12		mail system is full; otherwise this field shall be set to
13		'0'.
14	REPLY_ALLOWED	- Reply allowed flag.
15		This field shall be set to '1' if a reply to the voice mail
16		message is allowed; otherwise this field shall be set to
17		'0'.
18	FAX_INCLUDED	- Fax included flag.
19		This field shall be set to '1' if a fax is included with the
20		voice mail message; otherwise this field shall be set to
21		'0'.
22	VM_LENGTH	- Voice mail length.
23		For voice mail messages shorter than 4095 seconds,
24		this field shall be set to the length of the voice mail
25		message in seconds. For voice mail messages 4095
26		seconds or longer, this field shall be set to
27		'111111111111'.
28	VM_RETENTION_DAYS	- Voice mail retention time.
29		This field shall be set to the number of days after
30		which the voice mail message is anticipated to be
31		deleted from the voice mail system.
32	VM_MESSAGE_ID	- Voice Mail Message ID.
33		This field shall be set to the message ID of the voice
34		mail message.
35	VM_MAILBOX_ID	- Voice Mailbox ID.
36		This field shall be set to the voice mailbox ID.
37	AN_DIGIT_MODE	- Voicemail access number digit mode indicator.

1		This field indicates whether the voicemail access
2		number digits are 4-bit DTMF codes or 8-bit ASCII
3		codes.
4		To specify the voicemail access number using the
5		binary representation of DTMF digits, this field shall
6		be set to '0'. To specify the voicemail access number
7		using ASCII characters, this field shall be set to '1'.
8	AN_NUMBER_TYPE -	Type of number used for voicemail access number.
9		This field shall be set to the AN_NUMBER_TYPE value
10		shown in [10] Table 2.7.1.3.2.4-2 corresponding to the
11		type of the number as defined in [6].
12	AN_NUMBER_PLAN -	Numbering plan for voicemail access number.
13		If the AN_DIGIT_MODE field is set to '1', this field shall
14		be set to the AN_NUMBER_PLAN value shown in [10]
15		Table 2.7.1.3.2.4-3 corresponding to the requested
16		numbering plan. If the AN_DIGIT_MODE field is set to
17		'0', this field shall be omitted.
18	AN_NUM_FIELDS -	Number of voicemail access number digits in this
19		subparameter.
20		This field shall be set to the number of voicemail
21		access number digits included in this subparameter.
22	AN_CHARi -	A voicemail access number digit or character.
23		This subparameter shall include AN_NUM_FIELDS
24		occurrences of this field. If the AN_DIGIT_MODE field
25		is set to '0', each occurrence of this field shall be set to
26		the code value shown in [10] Table 2.7.1.3.2.4-4
27		corresponding to the voicemail access number digit. If
28		the AN_DIGIT_MODE field is set to '1', each
29		occurrence of this field shall be set to the ASCII
30		representation corresponding to the voicemail access
31		number digit, as specified in [7], with the most
32		significant bit set to '0'.
33	CLI_DIGIT_MODE -	Calling Party Number Digit mode indicator.
34		This field indicates whether the calling party number
35		digits are 4-bit DTMF codes or 8-bit ASCII codes.
36		To specify the calling party number using the binary
37		representation of DTMF digits, this field shall be set to
38		'0'. To specify the calling party number using ASCII
39		characters, this field shall be set to '1'.
40	CLI_NUMBER_TYPE -	Type of number used for calling party number.

1			This field shall be set to the CLI_NUMBER_TYPE value
2			shown in [10] Table 2.7.1.3.2.4-2 corresponding to the
3			type of the number as defined in [6].
4	CLI_NUMBER_PLAN	-	Numbering plan for calling party number.
5			If the CLI_DIGIT_MODE field is set to '1', this field
6			shall be set to the CLI_NUMBER_PLAN value shown in
7			[10] Table 2.7.1.3.2.4-3 corresponding to the
8			requested numbering plan. If the CLI_DIGIT_MODE
9			field is set to '0', this field shall be omitted.
10	CLI_NUM_FIELDS	-	Number of calling party number digits in this
11			subparameter.
12			This field shall be set to the number of calling party
13			number digits included in this subparameter. If the
14			calling party number is unavailable, this field shall be
15			set to 0.
16	CLI_CHARi	-	A calling party number digit or character.
17			This subparameter shall include CLI_NUM_FIELDS
18			occurrences of this field. If the CLI_DIGIT_MODE field
19			is set to '0', each occurrence of this field shall be set to
20			the code value shown in [10] Table 2.7.1.3.2.4-4
21			corresponding to the calling party number digit. If the
22			CLI_DIGIT_MODE field is set to '1', each occurrence of
23			this field shall be set to the ASCII representation
24			corresponding to the calling party number digit, as
25			specified in [7], with the most significant bit set to '0'.
26	RESERVED	-	Reserved bits.
27			This field shall contain the number of bits required to
28			make the entire subparameter an integer number of
29			octets in length. All bits of this field shall be set to
30			zero.
31			

4.5.24 Enhanced VMN Ack

The Enhanced VMN Ack subparameter includes enhanced VMN message synchronization information. The voice mail system sends the Enhanced VMN Ack subparameter in a Voice Mail Notification (see 4.3.5) in order to acknowledge voice mail messages that have been deleted and to acknowledge voice mail messages that have been played.

The Enhanced VMN Ack subparameter has the following variable-length format:

Field	Length (bits)
SUBPARAMETER_ID	8
SUBPARAM_LEN	8
VM_MAILBOX_ID	16
VM_NUM_UNHEARD_MESSAGES	8
NUM_DELETE_ACKS	3
NUM_PLAY_ACKS	3

NUM_DELETE_ACKS occurrences of the following field:

DA_VM_MESSAGE_ID	16
------------------	----

NUM_PLAY_ACKS occurrences of the following field:

PA_VM_MESSAGE_ID	16
------------------	----

The subparameter ends with the following field:

RESERVED	0-7
----------	-----

SUBPARAMETER_ID - Subparameter identifier.

This field shall be set to '00010111'.

SUBPARAM_LEN - Subparameter length.

This field shall be set to the number of octets in the subparameter, not including the SUBPARAMETER_ID and SUBPARAM_LEN fields.

VM_MAILBOX_ID - Voice Mailbox ID.

This field shall be set to the voice mailbox ID of the voice mailbox for which message deletions are being acknowledged.

VM_NUM_UNHEARD_MESSAGES - Number of Unheard Voice Mail Messages.

This field shall be set to the number of unheard voice mail messages stored at the Voice Mail System, in the range 0-255.

1	NUM_DELETE_ACKS -	Number of Delete Acknowledgements.
2		This field shall be set to the number of
3		acknowledgements of message deletions.
4	NUM_PLAY_ACKS -	Number of Play Acknowledgements.
5		This field shall be set to the number of
6		acknowledgements of messages that have been played.
7	NUM_DELETE_ACKS occurrences of the following field shall be included, one for each	
8	message whose deletion is being acknowledged.	
9	DA_VM_MESSAGE_ID -	Voice Mail Message ID.
10		This field shall be set to the voice mail message ID of
11		the voice mail message whose deletion is being
12		acknowledged.
13	NUM_PLAY_ACKS occurrences of the following field shall be included, one for each	
14	message whose playing is being acknowledged.	
15	PA_VM_MESSAGE_ID -	Voice Mail Message ID.
16		This field shall be set to the voice mail message ID of
17		the voice mail message whose playing is being
18		acknowledged.
19	RESERVED -	Reserved bits.
20		This field shall contain the number of bits required to
21		make the entire subparameter an integer number of
22		octets in length. All bits of this field shall be set to
23		zero.

1 ANNEX A Enhanced Voice Mail Notification DTMF Commands

2 This **informative** annex provides a way of implementing the DTMF Commands for enhanced
 3 voice mail. A mobile station that supports enhanced voice mail notification uses DTMF
 4 tones to signal the voice mail system. The DTMF tones are generated by the base station.
 5 In order to request that the base station generate DTMF tones, a mobile station sends the
 6 *Send Burst DTMF Message* to the base station (see 2.7.2.3.2.7 of [10]).

7 A.1 Connection to the Voice Mail System

8 In order to connect to a voice mail system using enhanced voice mail notification, the
 9 mobile station shall initiate a call to the number represented by the occurrences of the
 10 AN_CHARi field in the Enhanced VMN Subparameter (see 4.5.23).

11 After the mobile station is connected to the voice mail system, if the mobile station is
 12 required to use a password for the voice mailbox, the mobile station shall request that the
 13 base station generate the DTMF codes corresponding to voice mail password associated
 14 with the mailbox followed by the “#” DTMF code.

15 A.2 Enhanced Voice Mail Notification DTMF Commands

16 Table A.2-1 includes the DTMF codes of DTMF commands that may be used for enhanced
 17 voice mail.

18
 19 **Table A.2-1. Enhanced Voice Mail Notification DTMF Commands**

Command	DTMF code	Reference
Set Voice Mail Message ID	86	A.2.1
Delete Multiple Messages	87	A.2.2
Play	88	A.2.3
Pause Playback	89	A.2.4
Resume Playback	90	A.2.5
Skip Forward	91	A.2.6
Skip Backward	92	A.2.7
Delete Message	93	A.2.8
Reply to Message	94	A.2.9
Play Active Greeting	95	A.2.10
Record Active Greeting	96	A.2.11
Play Name	97	A.2.12
Record Name	98	A.2.13
Set Password	99	A.2.14

20 A.2.1 Set Voice Mail Message ID

1 In order to issue a DTMF command that operates on a voicemail message, the mobile
2 station shall first issue the Set Voice Mail Message ID DTMF command. When issuing a
3 Set Voice Mail Message ID DTMF command, the mobile station shall request that the base
4 station generate the following DTMF codes in order: the Set Voice Mail Message ID DTMF
5 code from Table A.2-1, the DTMF codes corresponding to the VM_MESSAGE_ID field from
6 the Enhanced VMN Subparameter (base-10 digits in order of most significant to least
7 significant, without leading zeros) associated with the voice mail message (see 4.5.23), and
8 the “#” DTMF code.

9 A.2.2 Delete Multiple Messages

10 The mobile station issues the Delete Multiple Messages DTMF command in order to delete
11 multiple voice mail messages. When issuing a Delete Multiple Messages DTMF command,
12 the mobile station shall request that the base station generate the following DTMF codes in
13 order: the Delete Multiple Messages DTMF code from Table A.2-1, for each voice mail
14 message being deleted, the DTMF codes corresponding to the Voice Mail Message ID (base-
15 10 digits in order of most significant to least significant, without leading zeros) followed by
16 the ‘#’ DTMF code, and at the end of the list another ‘#’ DTMF code.

17 A.2.3 Play

18 The mobile station issues the Play DTMF command in order to play a voice mail message.
19 The mobile station shall only issue a Play DTMF command after issuing a Set Voice Mail
20 Message ID DTMF command (see A.2.1). When issuing a Play DTMF command, the mobile
21 station shall request that the base station generate the associated DTMF code from Table
22 A.2-1.

23 A.2.4 Pause Playback

24 The mobile station issues the Pause Playback DTMF command in order to pause playback
25 of a voice mail message. The mobile station shall only issue a Pause Playback DTMF
26 command after issuing a Set Voice Mail Message ID DTMF command (see A.2.1). When
27 issuing a Pause Playback DTMF command, the mobile station shall request that the base
28 station generate the associated DTMF code from Table A.2-1.

29 A.2.5 Resume Playback

30 The mobile station issues the Resume Playback DTMF command in order to resume
31 playback of a voice mail message. The mobile station shall only issue a Resume Playback
32 DTMF command after issuing a Set Voice Mail Message ID DTMF command (see A.2.1).
33 When issuing a Resume Playback DTMF command, the mobile station shall request that
34 the base station generate the associated DTMF code from Table A.2-1.

35 A.2.6 Skip Forward

36 The mobile station issues the Skip Forward DTMF command in order to skip forward in a
37 voice mail message. The mobile station shall only issue a Skip Forward DTMF command
38 after issuing a Set Voice Mail Message ID DTMF command (see A.2.1). When issuing a
39 Skip Forward DTMF command, the mobile station shall request that the base station
40 generate the associated DTMF code from Table A.2-1.

1 The amount of time that the voice mail system skips forward in the voice mail message is
2 left to the discretion of the operator.

3 A.2.7 Skip Backward

4 The mobile station issues the Skip Backward DTMF command in order to skip backward in
5 a voice mail message. The mobile station shall only issue a Skip Backward DTMF
6 command after issuing a Set Voice Mail Message ID DTMF command (see A.2.1). When
7 issuing a Skip Backward DTMF command, the mobile station shall request that the base
8 station generate the associated DTMF code from Table A.2-1.

9 The amount of time that the voice mail system skips backward in the voice mail message is
10 left to the discretion of the operator.

11 A.2.8 Delete Message

12 The mobile station issues the Delete Message DTMF command in order to delete a voice
13 mail message. The mobile station shall only issue a Delete Message DTMF command after
14 issuing a Set Voice Mail Message ID DTMF command (see A.2.1). When issuing a Delete
15 Message DTMF command, the mobile station shall request that the base station generate
16 the associated DTMF code from Table A.2-1.

17 A.2.9 Reply to Message

18 The mobile station issues the Reply to Message DTMF command in order to reply to a voice
19 mail message. The mobile station shall only issue a Reply to Message DTMF command
20 after issuing a Set Voice Mail Message ID DTMF command (see A.2.1). The mobile station
21 shall not generate a Reply to Message DTMF command after issuing a Set Voice Mail
22 Message ID DTMF command corresponding to a message with the REPLY_ALLOWED bit set
23 to '0' in the Enhanced VMN Subparameter (see 4.5.23). When issuing a Reply to Message
24 DTMF command, the mobile station shall request that the base station generate the
25 following DTMF codes in order: the Reply to Message DTMF code from Table A.2-1, the
26 DTMF codes corresponding to the occurrences of the CLI_CHARi field from the Enhanced
27 VMN Subparameter associated with the voice mail message (see 4.5.23), and the "#" DTMF
28 code.

29 In response to the Reply to Message DTMF command, the voice mail system prompts the
30 user to record a message.

31 A.2.10 Play Active Greeting

32 The mobile station issues the Play Active Greeting DTMF command in order to play the
33 active greeting. When issuing a Play Active Greeting DTMF command, the mobile station
34 shall request that the base station generate the associated DTMF code from Table A.2-1.

35 A.2.11 Record Active Greeting

36 The mobile station issues the Record Active Greeting DTMF command in order to record
37 the active greeting. When issuing a Record Active Greeting DTMF command, the mobile
38 station shall request that the base station generate the associated DTMF code from Table
39 A.2-1.

1 In response to the Record Active Greeting DTMF command, the voice mail system prompts
2 the user to record a greeting.

3 A.2.12 Play Name

4 The mobile station issues the Play Name DTMF command in order to play the name. When
5 issuing a Play Name DTMF command, the mobile station shall request that the base station
6 generate the associated DTMF code from Table A.2-1.

7 A.2.13 Record Name

8 The mobile station issues the Record Name DTMF command in order to record the name.
9 When issuing a Record Name DTMF command, the mobile station shall request that the
10 base station generate the associated DTMF code from Table A.2-1.

11 In response to the Record Name DTMF command, the voice mail system prompts the user
12 to record the name.

13 A.2.14 Set Password

14 The mobile station issues the Set Password DTMF command in order to set the voice mail
15 password. When issuing a Set Password DTMF command the mobile station shall request
16 that the base station generate the following DTMF codes in order: the Set Password DTMF
17 code from Table A.2-1, the DTMF codes corresponding to the digits of the password, the “#”
18 DTMF code, the DTMF codes corresponding to the digits of the password, and the “#”
19 DTMF code.